



---

# **USER'S GUIDE**

*English*

### ***PLEASE NOTE!***

For instructions in other languages please consult our webpage  
<http://www.cpen.com>.

### ***OBSERVERA!***

Manualer på andra språk finner du på vår webbplats  
<http://www.cpen.com>.

### ***BITTE BEACHTEN!***

Wenn Sie eine Anleitung in einer anderen Sprache beziehen  
möchten, besuchen Sie bitte unsere Web-Seite  
<http://www.cpen.com>.

### ***REMARQUE!***

Pour obtenir des instructions en d'autres langues, veuillez  
consulter notre page web <http://www.cpen.com>.

### ***NOTA!***

Para instrucciones en otros idiomas por favor consulte nuestra  
página web <http://www.cpen.com>.

First edition (January 2001).

This manual is published by C Technologies AB, without any warranty. Improvements and changes to this manual necessitated by typographical errors, inaccuracies of current information, or improvements to programs and/or equipment, may be made by C Technologies AB at any time and without notice. Such changes will, however, be incorporated into new editions of this manual including those on our web site [www.cpen.com](http://www.cpen.com).

All rights reserved

Copyright © C Technologies AB, 2001

Printed in Sweden and in the USA.

# Contents

<b>INTRODUCTION TO C-PEN .....</b>	<b>5</b>
C-Pen Models .....	5
Your Personal Digital Assistant .....	8
Optimal Reading Conditions .....	10
User Documentation and Support .....	12
Care and Safety .....	12
<b>PRESENTATION OF C-PEN .....</b>	<b>14</b>
Parts of C-Pen .....	14
Display Objects .....	18
<b>GETTING STARTED .....</b>	<b>21</b>
Turning C-Pen On and Off .....	21
Battery .....	21
Navigating and Selecting .....	25
<b>READING AND SAVING TEXT .....</b>	<b>28</b>
Reading Text .....	28
Saving Text .....	32
<b>EDITING TEXT .....</b>	<b>33</b>
Entering Edit Mode .....	33
Edit Menu .....	33
C Write .....	38
C Write Prototypes .....	42
<b>APPLICATIONS .....</b>	<b>46</b>
Notes .....	48
C Address .....	52
C Calendar .....	58
C Dictionary .....	72
C Message .....	81
Settings .....	89
Info .....	97
Storage .....	98
C Beam .....	100
C Direct .....	103
C Write .....	105

<b>USING C-PEN WITH YOUR PC .....</b>	<b>106</b>
Installing C-Win Software .....	106
Connecting C-Pen to a PC by IR .....	107
Connecting C-Pen to a PC by Cable .....	108
Getting Help .....	109
C-Pen Viewer .....	109
Copy and paste in the PC environment .....	110
Installing and Removing Applications .....	111
Transferring Files .....	112
C Address .....	113
C Direct .....	114
C-Pen Edit .....	114
Closing the Connection .....	114
<b>TECHNICAL SPECIFICATIONS .....</b>	<b>115</b>
<b>WARRANTY .....</b>	<b>116</b>
LIMITED WORLDWIDE WARRANTY .....	118
Warranty Information .....	118
<b>DECLARATION OF CONFORMITY .....</b>	<b>121</b>
<b>UL STATEMENT .....</b>	<b>122</b>
<b>C DICTIONARY COPYRIGHT NOTICE .....</b>	<b>123</b>
<b>INDEX .....</b>	<b>125</b>

# INTRODUCTION TO

Congratulations - you have just bought a photographic memory! C-Pen is a Mobile Information Collector that reads, remembers, processes and transfers printed text to your Windows-equipped PC and PDA products. C-Pen is in essence an electronic highlighter that saves the text you are marking. Carry it with you wherever you go!

Make it a habit to take your portable text collector with you, and you are always ready to read and save text from books, papers, brochures or business cards. You can easily record price-lists, timetables, wine tips or witty quotes. You don't have to tear out pages any more.

With the portable dictionary you can translate and look up words immediately without carrying around a printed dictionary!

Your saved text files can later be transferred to your PC. It is also possible to use C-Pen to read text directly into a Windows application in your PC.

## **C-Pen Models**

In order to accommodate different needs, several C-Pen models are available. They all have the basic features **C Read**, **C Write** and **Notes**. Some models are equipped with additional applications such as **C Dictionary**, **C Calendar**, **Storage** and **C Message**. The set of applications depends on the model. On the following pages you will find a short description of the different C-Pen models and their applications. For more information on C-Pen, please refer to our webpage: [www.cpen.com](http://www.cpen.com).

---

## C-Pen 600C

C-Pen 600C combines the reading function with translation ability, making it the perfect companion when traveling or studying.

C-Pen 600C includes:

- C Read
- C Direct
- C Address
- C Write
- Notes
- Info
- C Beam
- C Dictionary
- Storage



C-Pen 600C also offers communication by cable as well as by IR.

It is powered by two alkaline AAA batteries (1.5 V type, LR03). See further important instructions, **Battery**, p.21.

C-Pen 600C has a Trigg button, that you press while reading, and an ESC button. It is possible to exchange the functions between these two buttons.

For more information on C-Pen 600C, please refer to our webpage: [www.cpen.com](http://www.cpen.com).

---

## C-Pen 800C

C-Pen 800C has several additional features which make it a superior tool for use in your work and studies and when travelling.

C-Pen 800C includes:

- C Read
- C Write
- C Beam
- C Calendar
- C Direct
- Notes
- C Dictionary
- C Message
- C Address
- Info
- Storage



Communication is available by cable as well as by IR.

C-Pen 800C is powered by a rechargeable battery. The charging adapter is included in the C-Pen package.

The cable is used for both communication and for charging.

When reading with a C-Pen 800C you normally use the automatic trigger. The ESC button can, if you wish, be exchanged to a Trigg button, a manual trigger.

C-Pen 800C also has a time, a sound and an alarm function.

For more information on C-Pen 800C, please refer to our webpage: [www.cpen.com](http://www.cpen.com).

---

## Your Personal Digital Assistant

To see which of the below mentioned applications your C-Pen model has, see C-Pen models, p. 6-7.

### Powerful features

- **C Read**

Reads in text - the basic function of C-Pen. Move C-Pen over the text, and the text will be captured by the pen, where it can be saved as a file for later processing.

- **C Write**

Allows you to enter characters by writing with C-Pen as if it were an ordinary pen. This is useful when editing text, entering file names, looking up words in **C Dictionary** or searching for a contact in **C Address**.

- **C Address**

Stores and looks up contact information such as addresses, phone numbers and e-mail addresses. **C Address** can be synchronized with Microsoft® Outlook and supports the vCard standard.

- **C Direct**

Enables you to transfer the scanned text directly from C-Pen into your PC. The text will be placed at the cursor position in any Windows program.

- **C Beam**

Transfers notes, contacts, calendar events and files between C-Pen and PDAs. **C Beam** supports the standard infrared protocol IrOBEX and complies with both the vCard and vCalendar standards. All devices and appli-



---

cations using the IrOBEX protocol to its full extent are fully compatible with C-Pen.

- **C Calendar**

Works like a normal calendar with the advantage of displaying the information in many different ways once you have the information in your C-Pen. You can choose to view a whole month, a single week or a day and you can either read or write event/task information into your C-Pen.

- **C Dictionary**

Enables your C-Pen to translate and/or look up words. **C Dictionary** is very easy to use, simply slide your C-Pen over the word you require translated and within less than a second the result is displayed. Several language software packages are available.

- **C Message**

Sends text messages in combination with a mobile phone. With **C Fax** you can send fax messages, while **C SMS** is used when you want to send text messages, SMS, to a mobile phone or an e-mail to an e-mail account. You can either send complete files from **Notes** or write a short message with **C Write** into **C Message** and then send it. C Message requires a mobile phone that is equipped with an IR eye and a fax modem and that is using the GSM system.

- **Storage**

Storage area in C-Pen, which can be used as a floppy disc for files.

---

## Optimal Reading Conditions

C-Pen uses *Optical Character Recognition* (OCR) to read text. OCR is the process of turning an image of characters into computer-readable text.

As C-Pen moves over the text, its internal light source illuminates the characters and a camera takes pictures of the text. During OCR, C-Pen analyzes the pictures taken by its camera and translates them into text characters.

The OCR quality will depend on the reading conditions. The letters most commonly confused using OCR are:

e → c	l → I	t → c
r+n → m	i → l	c → o

The following conditions affect the quality of character recognition:

- **The print quality of the text**

High-quality printed text naturally gives maximum OCR accuracy. With lower-quality print, e.g. faxes, OCR accuracy may be poorer. You can calibrate the C-Pen to optimize its performance under difficult conditions; see **Calibration**, p. 91.

! *Please note* that C-Pen only recognizes machine-printed characters such as laser-printed or typewritten text.

• C-Pen does not recognize handwritten text.

- **Position and movement of C-Pen**

It is important how you hold and move C-Pen over the printed text. Please see **Reading and saving text**, p. 28 or read the Quick Start folder to learn how to use

---

C-Pen correctly. It is crucial that you follow these instructions in order to get the best results.

- **The language of the text**

Set the text language of the text you wish to read, to get the most suitable OCR. See **Text Language**, p. 90.

- **Deformed characters**

Anything that is not a printed character, and any character distorted by a mark or smudge on the paper may be unrecognizable.

- **Overlapping characters**

Characters in the text should not overlap.

- **Italics and underlined text**

Italics are slightly difficult for C-Pen to read in some fonts. Underlined text is also difficult for C-Pen to read because the underline changes the shapes of the descenders of the letters g, j, p, q and y.

- **Text colors - text and surface**

C-Pen cannot read some combinations of text colors on colored surfaces, such as red or yellow text on a white or red background.

Text that is highlighted by a traditional highlighter marker can be read in some cases, depending on the color and darkness of the ink.

- **Small or large character sizes**

The size of the characters should be 5–22 points.

---

## User Documentation and Support

There are several sources of support for your C-Pen.

This *User's Guide* contains a description of C-Pen, its applications and instructions for reading and editing text and saving files. The following applications are explained:

- C Read
- C Direct
- Storage
- C Write
- C Beam
- C Dictionary
- Notes
- Info
- C Calendar
- C Address
- Settings
- C Message

You can also learn how to connect C-Pen to a PC.

The enclosed C-Pen CD contains the C-Win Software for communication between C-Pen and your PC. It also contains several help files:

- *Help*
- *User's Guide* in several different languages
- *Troubleshooting*, which helps you solve many problems

On our web site, [www.cpen.com](http://www.cpen.com), you can find *Troubleshooting* and the *User's Guide* translated into several languages. Visit our web site, [www.cpen.com](http://www.cpen.com), to get the latest C-Pen news and free software upgrades.

## Care and Safety

- Keep C-Pen away from direct sunlight, heat, moisture and dust.
- Do not expose C-Pen to extreme temperature variations.

- 
- Make sure the camera opening is free from dust or any other objects.
  - Do not deliberately insert any object into the camera opening.
  - Clean C-Pen with a dry cloth. Do not use detergents or other chemicals when cleaning C-Pen.
  - C-Pen models that are powered by alkaline batteries, require two 1.5 V AAA batteries of type LR03. Rechargeable C-Pen models have a built-in battery which is to be recharged with C Technologies' recharging adapter. See **Battery**, p. 21.
  - Make backup copies of your C-Pen files regularly and keep the copies in a safe place. Copies are made using C-Win Software, see **Using C-Pen with your PC**, p. 106.

---

# PRESENTATION OF C-PEN

## Parts of C-Pen

There are some differences between the C-Pen models. The main differences concern the battery, the **ESC** button and the **Trigg** button. There is no battery compartment in a rechargeable C-Pen, since the battery is built-in. On a C-Pen that has an automatic trigger, an **Autotrigger**, the button on the front of the pen is the **ESC** button, while on the other models this is the **Trigg** button. For more information about your C-Pen model see **C-Pen models**, p. 6-7, **Technical Specifications**, p. 115 and the following pages.

Description of the different parts:

### C-Pen with a manual trigger

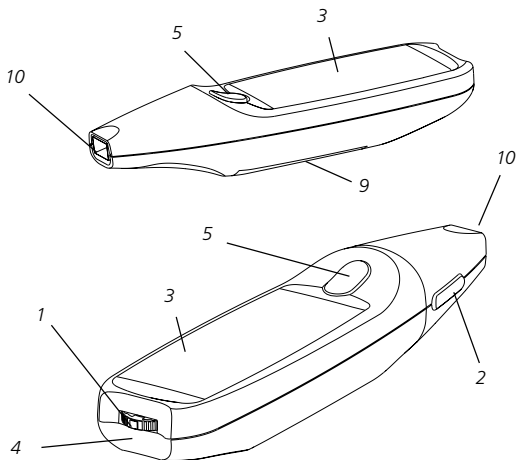

---

## C-Pen powered by AAA batteries

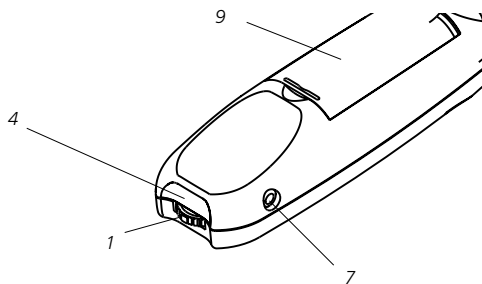

## C-Pen with an automatic trigger

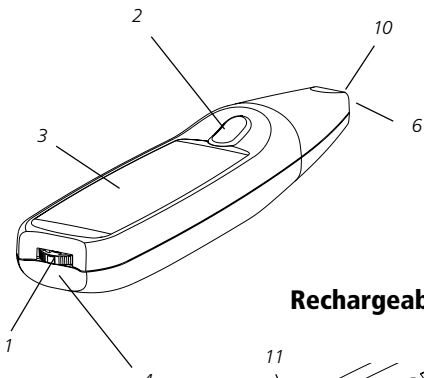

## Rechargeable C-Pen

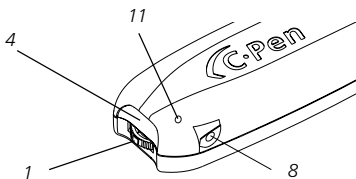

---

## 1. *On/Off and Nav*

Turns C-Pen on or off when pressed and held for more than two seconds. This button is also used to scroll through the menus and texts (push up or down) and to select an item or an option (press briefly).

## 2. *ESC*

Closes menus. Please note that this is the button on the top of a C-Pen with an automatic trigger, while it is, as default, the button on the side of C-Pen with a manual trigger.

## 3. *Display*

Used to display scanned text and for communication between C-Pen and the user. The orientation of the text on the display can be changed to suit left-handed users. See **System Settings**, p. 94.

## 4. *IR port*

The infrared (IR) port is used for wireless data transfer between C-Pen and a PC, mobile phone or PDA that is equipped with an IR port.

## 5. *Trigg*

On a C-Pen with a manual trigger, **Trigg** is to be pressed and held down while reading text. The functions of **Trigg** and **ESC** can be exchanged to suit your own preferences. See **System Settings**, p. 94. Some C-Pen models have an automatic trigger, **Autotrigger**, see figure p. 15.

## 6. *Autotrigger*

For a C-Pen with an automatic trigger, the **Autotrigger** is located at the rim of the camera opening. When reading correctly, the **Autotrigger** is pressed into the pen.



---

## ***7. Cable Socket***

The **Cable Socket** is where you plug in the cable that connects C-Pen to your PC. The cable is used to communicate and transfer files to and from C-Pen to your PC.

## ***8. Cable and Charging Socket***

For the rechargeable C-Pen the same cable is used for both communication and for charging. Insert the plug into this socket in order to recharge the battery and to communicate with your PC.

## ***9. Battery Compartment***

For a C-Pen that is powered with AAA batteries, this is where you insert the batteries.

## ***10. Camera Opening***

The **Camera Opening** is not protected in any way. This enhances C-Pen's reading ability but it also makes it important to see to that dust or other objects do not enter the camera opening.

## ***11. Reset Button Hole***

For a rechargeable C-Pen, if the pen seems to have "frozen" gently insert something similar to an unfolded paperclip into the **Reset Button Hole** and press. This will reset C-Pen.

For C-Pens that are powered by AAA batteries, the way to reset the pen is simply to remove the batteries from the battery compartment, and then replace them.

---

## Display Objects

C-Pen uses the following display objects to communicate with you:

- status field
- application icons
- menus
- check boxes
- dialog boxes
- edit fields
- dialog buttons

### Status field

The area on the left side of the display is called the status field. This field can display the time, current application, text settings (**Text Quality** and **Text Language**) and C-Pen's battery power level. See also **Settings**, p. 89 and **Battery**, p. 21.

The information displayed in the status field differs depending on the C-Pen model.

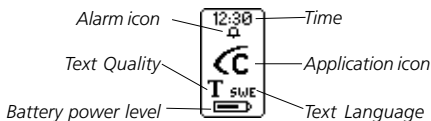

### Application icons

The applications are represented by application icons on the **main screen**. The applications are described in the chapter **Applications**, p. 46.



**C-Pen main screen**

*Application icons*

## Menus

Menus provide different options. A scroll bar indicates if there are more menu items available above or below the visible section.

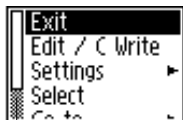

*Menu items*

**Menu**

*Scroll bar*

## Check boxes

Check boxes also provide different options. A check box remains checked until you uncheck it or check another of the alternative boxes in the list.

- Normal — *Checked box*
- Inverted — *Unchecked box*

---

## Dialog boxes

A dialog box appears when you need to enter information or give commands to C-Pen. A dialog box contains one or more objects such as edit fields or dialog buttons.

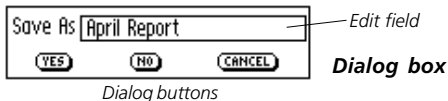

## Edit fields

It is possible to enter and edit text in an edit field. An edit field is recognized by its frame, see the figure above.

## Dialog buttons

Dialog buttons are used in dialog boxes to give simple instructions to C-Pen.



*Common dialog buttons*

---

# GETTING STARTED

## Turning C-Pen On and Off

To turn C-Pen on and off, press the **On/Off** button until the display is activated/deactivated. C-Pen turns off automatically after 5 minutes of inactivity. To change the automatic power-off time, see **System Settings**, p. 94.

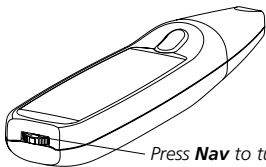

Press **Nav** to turn C-Pen on and off

## Battery

### C-Pens powered by AAA batteries

#### Installing the batteries

1. Remove the battery cover from the back of C-Pen.

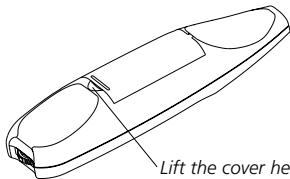

Lift the cover here to open

- 
- ! It is imperative to **observe the polarity of the batteries**. The orientation of the plus and minus ends is shown inside the battery compartment.

2. Insert two alkaline AAA batteries (1.5 V, type LR03).

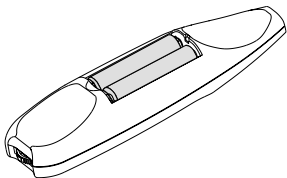

3. Replace the battery cover. You should hear a “click” when it locks in place.

- ! **Please** do not dispose of batteries in a fire as there is a **danger of explosion**. Please **recycle** the batteries!

### Battery power level

The battery power level is shown by the battery indicator at the bottom of the status field.

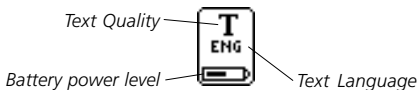

If the battery power level is getting low, the message “*Battery low*” will appear on the display. To avoid losing unsaved information, save all material not previously saved and then change the batteries. Turn C-Pen off before changing batteries. To change batteries, see **Installing the batteries** p. 21.

---

If the battery power level is so low that the pen can no longer function, you will get the message “*Battery level too low! Shutting down.*” You must change the batteries to be able to continue using C-Pen.

**! Please note** that information may be lost if you remove the batteries without turning C-Pen off first. However, when you turn C-Pen off properly, all information is saved in the memory and it is safe to remove the batteries.

C-Pens that are powered by alkaline batteries are reset by removing the batteries from the battery compartment. Do this when C-Pen has encountered problems or has “frozen”.

## Rechargeable C-Pens

### Battery power level

The battery power level is shown by the battery indicator at the bottom of the status field.

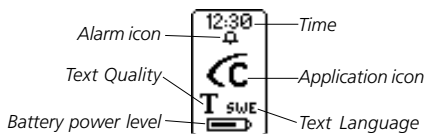

If the battery power level is getting low, the message “*Battery level low*” will appear on the display. You should recharge the battery to ensure that information which has not previously been saved will not be lost.

In order to recharge the battery, insert the charging adapter’s plug into the C-Pen charging socket. The charging adapter is included in the C-Pen package. It is possible to recharge

---

the C-Pen both when it is turned on and when it is turned off. While recharging, the battery power level icon indicates this by *moving back and forth* in the status field.

Charging is completed when the battery power level icon *stays steady*. Charging normally takes about 1.5 h.

**Please note** that C-Pen will recharge only if the room temperature is between +5 and +45°C (+41 and +113°F).

- ! For temperatures above +35°C (+95°F) the recharging process will take a little longer (1.5 - 2.5 h). For temperatures below +5°C (+41°F) the recharging process will cease, but will continue if the temperature rises above +5°C (+41°F).

When the battery is not charging the indicator is stationary.

### **If recharging does not start**

If the charger is connected to C-Pen and the recharging process does not start, follow these instructions.

1. Disconnect the charger from your C-Pen.
2. Insert something thin (like an unfolded paperclip) into the **reset hole** and press gently, see figure on p. 15.
3. Reconnect the charger to C-Pen.
4. C-Pen should begin recharging the battery within 10 seconds. If recharging does not start (the battery power level icon is not moving in the status field) please repeat steps 1-3 above. Remember to make sure that the charger is not connected to C-Pen while pressing the reset button.



---

If C-Pen has encountered problems or has “frozen”, insert something thin (like an unfolded paperclip) into the reset hole and press gently, see p. 15.

## Navigating and Selecting

**Nav** (the navigation control) is used for navigation and to select an object.



*Turn to navigate between fields*

*Press to select an object*

Turn **Nav** up or down to navigate between

- menu items
- dialog buttons
- edit fields
- check boxes
- lines or characters in text

As you move between objects, they become highlighted (inverted).

Pressing **Nav** briefly when an object is highlighted is referred to as *selecting* that object.

The result when selecting an object is explained for each situation later in this manual. Below are some general remarks about selecting objects.

---

## Menus

Selecting a menu item marked with a ► will display further alternatives in a new menu.

Selecting **EXIT** or **CANCEL** will close the menu. Instead of selecting **EXIT** or **CANCEL**, you can press **ESC**.



## Dialog buttons

In a dialog box you can instruct C-Pen how to continue by selecting a dialog button:

- **OK**

You accept a suggestion in a dialog box.

- **YES**

Your answer is “Yes” to a question in a dialog box.

- **NO**

Your answer is “No” to a question in a dialog box.

- **CANCEL**

The dialog box is closed and you return to your earlier menu or screen. Instead of selecting **CANCEL**, you can press **ESC**.

## Edit fields

To be able to edit text in an edit field, you must first select the field.

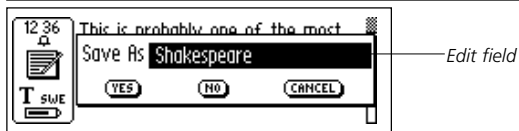

A cursor will appear in the edit field and the status field will show the edit mode symbol. See **Editing text**, p. 33.

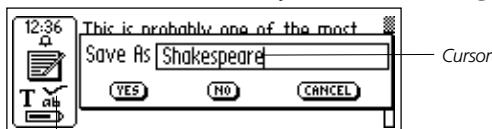

*Edit mode symbol*

## Check boxes

To mark an alternative in a list of check boxes, navigate to the alternative of your choice (using the **Nav** button).



Mark the alternative by selecting it (press the **Nav** button briefly).



The check box becomes checked and the **OK** button is highlighted. Press **OK** if you are satisfied with your choice, otherwise press **CANCEL**.

---

## READING AND SAVING TEXT

Please follow the instructions in this chapter in order to get the best results from your C-Pen. Take a few minutes to learn how to use C-Pen correctly. See also **Optimal Reading Conditions** p. 10.

In this *User's Guide* “read text” should be interpreted as reading a line of text, not a line on C-Pen’s display.

### Reading Text

#### C-Pen with a manual trigger

To read a line, follow the steps below.

1. Turn C-Pen on. Make sure the text settings are set to the appropriate values. The text settings are **Text Language**, **Read Mode** and **Text Quality**. It is also possible to calibrate C-Pen for best performance. See **Settings**, p. 89.
2. Place C-Pen over the first character you want to read. Hold C-Pen with the pen tip *flat* against the surface. Make sure that the camera opening covers the entire height of the line. C-Pen reads one line at a time.

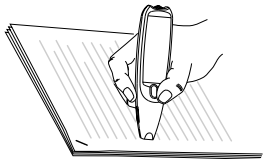

3. Press and hold **Trigg**.

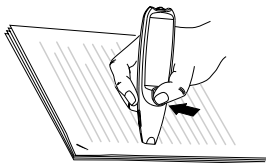

- ! **Please note** that the text surface must be completely flat in order to achieve maximum reading accuracy.

4. Move C-Pen over the line of text, keeping **Trigg** pressed. You can move C-Pen left-to-right or right-to-left over the text. You can read up to 15 cm/second (6 inches/second).

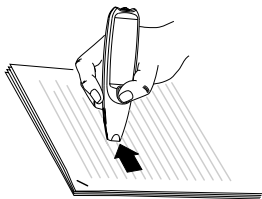

5. Release **Trigg** at the end of the line.

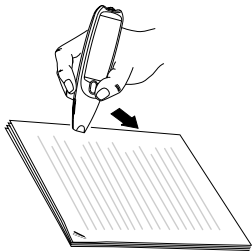

---

## C-Pen with an automatic trigger

This C-Pen model has an **Autotrigger** in order to facilitate the reading process. To read a line, follow the steps below.

1. Turn on C-Pen. Make sure that the text settings are set to the appropriate values. The text settings are **Text Language**, **Read Mode** and **Text Quality**. It is also possible to calibrate C-Pen for best performance. Refer to **Settings**, p. 89.
2. Place C-Pen over the first character you want to read. Hold C-Pen with the pen tip *flat* against the surface. Aim at the center of the line. C-Pen reads one line at a time.

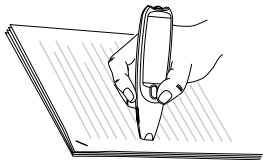

- ! **Please note** that the text surface must be completely flat in order to achieve maximum reading accuracy.
3. Move C-Pen over the line of text. Keep the pen tip flat against the surface while reading. Make sure the **Autotrigger** (at the pen tip) is pressed. You can move C-Pen left-to-right or right-to-left over the text. You can read up to 15 cm/second (5 inches/second).

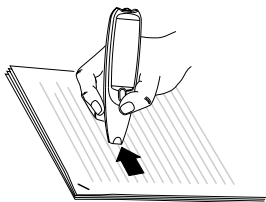

4. Lift the pen at the end of the line in order to release the pen's **Autotrigger**.

### Continued reading

The **Text screen** will appear on the display.

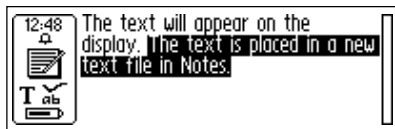

*Text screen*

The text is placed in a new text file in **Notes**, see p. 48. You can also create a new, empty text file by selecting **New...** and then **FILE** in **Notes**, before you start reading.

### Reading another line

Read the second line in the same way as you read the first. A space, a line break or a tab is inserted between the lines, see **Read Mode**, p. 89. You can insert a line break by pressing **Trigg** (C-Pen with a manual trigger) or **Autotrigger** (C-Pen with an automatic trigger).

The last line is highlighted (negative), i.e. light text on a dark background. To delete the last line, press **ESC** briefly.

---

## Deleting a line

To delete any of the lines you have read, proceed as follows.

1. Move the cursor (the flashing triangle) with the **Nav** button to the beginning of the line. Press **Nav** and the **Text menu** opens, see p. 50.
2. Scroll through the menu items until you find **Select** and press **Nav**. The line becomes highlighted.
3. Press **ESC** briefly. The line disappears and you are ready to read a new line.

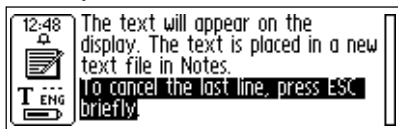

## Saving Text

Press **Nav** to open the **Text menu** (see **Notes**, p. 48) and choose **Exit**. The **Save As** dialog box appears. Choose **YES** if you want to save the text, **NO** if you want to discard the text or **CANCEL** if you want to return to the text. The dialog box contains an edit field with a suggested file name. You can change the file name before you save the file; see **Editing text** in the next section.



---

## EDITING TEXT

To be able to edit text in a text file or in an edit field you must enter **edit mode**.

### Entering Edit Mode

You can enter **edit mode** in different ways depending on your starting-point. You can enter edit mode from the Text screen or from an edit field.

### Entering edit mode from the Text screen

Press **Nav** in the Text screen to open the Text menu. Select **Edit/C Write** to enter **edit mode**. You can now edit text either by using the Edit menu (see below) or by using **C Write** (see p. 38).

### Entering edit mode in an edit field

Press **Nav** when the edit field is highlighted to enter edit mode. You can now edit text either by using the Edit menu (see below) or by using **C Write** (see p. 38).

### Edit Menu

When you are in edit mode a cursor appears and the edit mode symbol is shown in the status field.

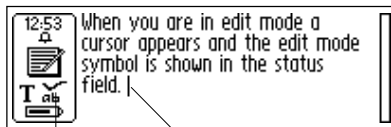

*Edit mode symbol*    *Cursor*

---

In edit mode you can move the cursor one character at a time by turning **Nav**. You can move to the beginning or the end of the text with the **Go to** option in the **Edit menu**. Move the cursor to the position where you want to edit the text. Press **Nav** to open the **Edit menu**.



*Edit menu*

The options in the **Edit menu** are slightly different, depending on whether you want to edit a field in **C Address** or a text in **Notes**. The most common items in the **Edit menu** are:

- **Quit Editing**

Exits edit mode in the **Text screen**.

- **Done**

Returns to the text from the edit mode in an edit field.

- **Change**

Changes the character to the right of the cursor.

- **Insert ▶**

Inserts new characters, a space or a line break at the cursor's position.

- **Cut**

Cuts out the selected characters.

- **Copy**

Copies the selected characters.

---

- **Paste**

Pastes a cut out or copied selection of characters.

- **Delete**

Deletes a character or a selection of characters.

- **Go to▶**

Moves the cursor to the beginning or the end of the text.

- **Select▶**

Highlights characters or an entire text.

- **Settings▶**

Sets the text settings (**Text Language**, **Text Quality** and **Read Mode**) of the text you are reading. The options **Calibration** and **C Write Feedback** are also included here.

- **Cancel**

Closes the edit menu. Returns to the read text.

The menu items are explained in greater detail below.

## Change

Place the cursor to the left of the character you want to change and select **Change** from the menu. Turn **Nav** to select the new character from the character set and then press **Nav**.

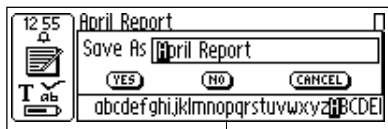

*The character set*

---

As default **C Write Prototype Viewing** is enabled. When scrolling in the character set you can see how the characters should be drawn if you want to use C-Pen as a normal pen during editing. **C Write Prototype Viewing** is automatically turned on/off when **C Write Feedback** is turned on/off, see p. 39.

## Insert

Move the cursor to the place where you want to insert text, and select **Insert** from the menu. You can choose between inserting a space, a line break, a character or multiple characters.

Select **Character** in the **insert menu** to insert one character. Then turn **Nav** to select a character from the character set and press **Nav**. The character set closes automatically after insertion.

To insert more than one character, select **Multiple Characters**. Turn **Nav** to select a character from the character set and press **Nav**. The character set remains on the display and you can continue inserting characters.

As default **C Write Prototype Viewing** is enabled. When scrolling in the character set you can see how the characters should be drawn if you want to use C-Pen as a normal pen during editing. **C Write Prototype Viewing** is automatically turned on/off when **C Write Feedback** is turned on/off, see p. 39.

When you are finished, press **ESC** or the **DONE** button (in the end of the character set) to return to the text you are editing.

---

## Select

Use the **Select** command to edit more than one character at a time. Then select **Characters** and turn **Nav** to mark multiple characters. Press **Nav** and choose **Cut**, **Copy** or **Delete** from the menu. If you select **All**, the entire text will be selected.

## Cut, Copy and Paste

To be able to choose **Cut**, **Copy** or **Paste** you must have selected part of a text. If you have chosen **Cut** or **Copy** you can **Paste** the text section at the cursor's position by pressing **Nav** and selecting **Paste** in the menu.

## Delete

Place the cursor to the left of the character you want to delete and select **Delete** from the menu. If you have selected several words or lines, the whole selection will be deleted, see **Select** above.

## Settings

Detailed explanations of the settings are to be found in **Settings**, p. 89. The available settings are:

- **C Write Feedback**

Mark/unmark the check box to switch the **C Write** visual feedback on/off. See p. 39.

- **Text Language**

Select the language of the text you are reading.

- **Read Mode**

Select **Continuous** or **Separate lines**.

---

- **Text Quality**

Select **Normal** or **Inverted**.

- **Calibration**

You can either calibrate C-Pen or revert to the default setting.

## **Quit Editing**

Quit edit mode by selecting **Quit Editing**.

## **C Write**

**C Write** is a feature that allows you to draw characters by using C-Pen as an ordinary pen. C-Pen can track its own movement over a surface and recognize the movement as a letter, digit or a symbol. **C Write** is an alternative to using the character set when inserting characters in a text.

- ! *Please note* that to be able to use **C Write**, the surface you “write” on must have a distinct pattern. Printed text is the best choice.

Use **C Write** in the following way:

1. Enter **edit mode**.
2. Position the cursor on C-Pen’s display.
3. Place C-Pen with the pen tip flat against a text surface.
4. Form a letter, see **C Write Prototypes**, p. 42. When using a C-Pen with a manual trigger, the **Trigg** button must be pressed while forming the letter.
5. Lift the pen from the surface. When the pen is lifted from the surface an image will briefly appear on the display, showing the letter as perceived by your C-Pen.

---

You do not have to wait for this image to disappear to write your next letter. The function is called **C Write Feedback**, and is enabled as default.



*Visual feedback*

The **C Write Feedback** utility can be switched on/off as follows.

1. Go to **Settings** in the **main screen**.
2. Select **C Write Feedback**.
3. Uncheck/check the check box according to your personal preference.
4. Select **OK**.

### **Basic rules when using C Write**

It is important that the pen tip is in contact with the surface while you are writing. For a C-Pen with a manual trigger **Trigg** must be pressed *before* you start writing.

The writing surface must have a distinct pattern, such as a printed text. Solid colors or simple repetitive patterns (lines, squares, grids) should be avoided.

---

In order to obtain maximum accuracy when writing with C-Pen, your characters should resemble the prototypes on the following pages as closely as possible.

A character must be drawn in *one single stroke*. The dot indicates the starting point of the stroke, see next page.

The height of the character should be 1 - 4 cm (1/4 - 1 1/4 inch).

## Capital letters



When you enter edit mode the status field will change appearance. The edit mode symbol indicates that **C Write** will generate lowercase letters.

**C Write** Lowercase icon



To write a capital letter, you have to write the shift sign first, see **C Write Prototypes**. Only the first letter will be a capital. The status field will reflect this choice.

**C Write** Capital letter icon



If you write two shift signs, **C Write** will enter Caps Lock mode. All letters will be capitals until you write a shift sign again.

**C Write** Caps Lock mode icon

## Symbols

When using a C-Pen with a manual trigger, press **Trigg** briefly to enter symbol mode.



---

When using a C-Pen with an automatic trigger, press the pen tip briefly against the surface to enter symbol mode. The **Autotrigger** at the rim of the pen must be pressed into the pen.





















The status field displays the Symbol mode icon. Write one of the symbols in the symbol table. After writing a symbol, C-Pen automatically returns to normal mode.





















**C Write** *symbol mode icon*

If you want to quit symbol mode without writing a symbol, you have to draw a backspace symbol.

## C Write Prototypes



*Letters, digits and shift*

Shift	Space	Backspace	New line	
				
Aa	Bb	Cc	Dd	Ee
				
Ff	Gg	Hh	Ii	Jj
				
Kk	Ll	Mm	Nn	Oo
				

Pp	Qq	Rr	Ss	Tt
				
Uu	Vv	Ww	Xx	Yy
				
Zz				
				
1	2	3	4	5
				
6	7	8	9	0
				

---







## Special characters

Çç	Ææ	Øø			
					

## Accents and umlauts







Write the letter first and then the accent or umlaut.

























Example: ä=a+ 

¨	°	^	´	`	~
					

## Symbols

Enter symbol mode by pressing **Trigg** or the **Autotrigger** briefly.

.	,	:	;	/	\
					

(	)	[	]	{	}
					
-	+	*	\$	@	“
					
#	_	<	>	?	;
					
!	;	£	§	ß	%
					

# APPLICATIONS

C-Pen's application icons are shown on the **main screen**. You can move between the icons by using **Nav**. Press **Nav** to start an application.

To see which of the below mentioned applications that comes with your C-Pen, see **C-Pen models**, p. 6-7.



*C-Pen main screen*



Notes

**Notes** contains your read and stored text files. See p. 48.



C Address

**C Address** is an address book, where you can store business cards and search for contact information. **C Address** can be synchronized with Microsoft® Outlook on a PC, and with PDA devices, see **C Beam**, p. 52 and 113.



C Calendar

**C Calendar** works like a normal calendar with the advantage of displaying the information in many different ways once you have the information in your C-Pen. See p. 58.



C Dictionary

**C Dictionary** can read and translate words between the languages you have chosen for your C-Pen. See p. 72.



C Message

**C Message** is used to send SMS, e-mail and fax messages in combination with a mobile phone. See p. 81.



**Settings** contains parameters which can be changed such as power-off time and reading options. See p. 89.



**Info** contains information about your C-Pen's serial number, OS (Operating System) version, free memory space, etc. See p. 97.



**Storage** can store files for transfer between computers. See p. 98.



**C Direct** contains information on how to transfer text from C-Pen directly into a Windows program. See p. 103 and 114.



**C Beam** is used to transfer notes, contacts, calendar events and files between C-Pen and PDAs (Personal Digital Assistant). **C Beam** supports the standard infrared protocol IrOBEX and complies with both the vCard and vCalendar standards. See p. 100.



**C Write** contains information about and examples of how to write letters with C-Pen. See p. 38 and 105.

---

## Notes

**Notes** contains the text files you have read and saved. Enter **Notes** by selecting the **Notes** icon on the **main screen**.



*Your list of text files starts here*

Inside **Notes**, move between items using **Nav**.

You can transfer files from **Notes** in C-Pen to your PC. To do this, C Win Software must be installed on your PC. See **Using C-Pen with your PC**, p. 106.

### Creating a new file or folder

Selecting **New...** will open a dialog box. Select **FILE** to create a new file.



**!** *Please note* that if you are in the **main screen** or in **Notes** you do not have to execute this command to create a new file. A new file will automatically be created when you start to read with C-Pen (except when you are already in the **Text screen**). New text files will be placed in **Notes**.

Select **FOLDER** to create a new folder. A dialog box appears. Select the edit field to give the folder a name. Use C-Pen to read a name or press **Nav** to enter edit mode and



then write a name with **C Write**. To save the folder, select **OK**. The folder will be placed in **Notes**.

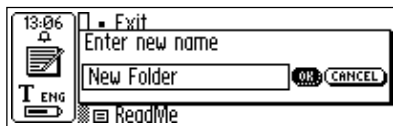

If you want to save a file in a specific folder, you must create the file in that folder. Open the folder, select **New...** and then select **FILE** in the dialog box.

## The Command menu

The **Command menu** contains commands for handling texts. Open the menu by selecting a text file and pressing **Nav**.



*Command menu*

The options in the **Command menu** are:

- **Open**

Opens the selected file.

- **Rename**

Renames the selected file. A dialog box with an edit field appears.

- **Delete**

Removes the selected file.

---

- **Properties**

Displays the file size, and if applicable the creation date and the date of last modification of the selected file.

- **Send** ▶

Only applicable if C Message is available. Opens a new menu in which, you can choose to send the file as SMS, SMS-Email or as a fax message.

- **Beam**

Transfers the selected file by IR, see p. 100.

- **Cancel**

Closes the **Command menu**.

## The Text menu

In the **Text screen** you can move the cursor line by line with **Nav**. You can insert a new line at the cursor position (the flashing triangle) by reading a new line with C-Pen.



*Text menu*

Press **Nav** if you want to edit the text, go to the beginning or end of the text, change text settings or stop working with the text. Pressing **Nav** opens the **Text menu**.

---

The items in the **Text menu** are:

- **Exit**

Closes the text. If the text has been changed you are prompted to save it before it is closed.

Select **SAVE AS...** if you want to save the changed file with a new name.

- **Edit/C Write**

Enters edit mode. See p. 33.

- **Settings▶**

Opens the text settings of the text you are reading. See **Settings**, p. 89.

- **Select**

Highlights a read line/word.

- **Go to▶**

Moves the cursor to the beginning or the end of the text.

- **Cancel**

Closes the **Text menu**.

---

## C Address

**C Address** is an application in C-Pen for storing and looking up contact information such as the addresses, phone numbers and e-mail addresses of people and organizations you communicate with.

The number of addresses that a C-Pen can store is 1000. When the number of contacts exceeds 50 they will automatically be divided into folders.

Start **C Address** by selecting the **C Address** icon on the **main screen**.



*C-Pen  
main screen*

The **C Address main screen** will open:

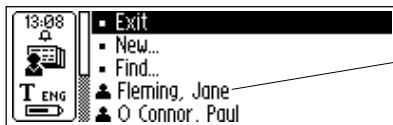

*Contact list  
C Address  
main screen*

Below the menu items **Exit**, **New...** and **Find**, your contacts are listed.

### Enter a new contact

To enter a new contact, select **New...** in **C Address main screen**. The **Contact edit screen** will open.

In the **Contact edit screen**, turn **Nav** to go to the first field, called **First name**. Read the first name of your contact with your C-Pen, for instance from a business card or a tele-

phone list, turn **Nav** to move to the next field, **Last Name**. Continue reading text into the following fields in the same way.

*Contact edit screen*

You can always move to any field you want by turning **Nav**. If you want to change a field that you have entered, just go to the field that you want to change and read again. Enter edit mode if you want to edit the contents of the field, see p. 33.

You can change the choice of contact details (addresses, phone numbers, e-mail addresses etc.) in **OPTIONS**. Select **OPTIONS** and scroll through the options. Check or uncheck the boxes according to your personal preferences. When you are finished, select **OK** or just press **ESC**.

*Check boxes*

You can discard the information you have entered in a contact file by selecting **CANCEL**. If you want to discard all changes select **YES** when a dialog box appears.

Selecting **TOP** at the end of the field list brings you to **SAVE**. If you choose **SAVE**, the changes will be saved and then the **Contact edit screen** automatically closes.

---

Select **SAVE** when you are finished. The **Save as** dialog box appears. The suggested file name is the name you entered in the **Full name** field. If this field is empty or unchecked the suggested file name will be “**Last name, First Name**”. You can edit the file name or you can read a new file name with your C-Pen.

A file name must not be longer than 64 characters. Invalid characters like ‘\’ or ‘.’ will be replaced with a blank space. If the file name already exists, a number suffix will be added to the file name, i.e. ‘John Mills (2)’ if ‘John Mills’ already exists.

Select **YES** to save the contact file. A new contact is added to your contact list.

## The contact menu

The **Contact menu** contains options for working with contact files. Open the menu by selecting a contact in the contact list.



*Contact menu*

The options in the **Contact menu** are:

- **View**

Lets you view the information you have entered on a contact.

---

- **Edit**

Lets you edit the information you have entered on a contact.

- **Delete**

Deletes the contact file.

- **Rename**

Renames the contact file.

- **Beam**

Transfers the selected contact file by IR, see p. 100.

- **Top (Exit)**

Brings you to the top of the **C Address main screen**.

- **Cancel**

Closes the **Contact menu**.

## View a contact

Select **view** to look at a contact. The contact information is presented in the **Contact view**. Turn **Nav** to scroll through all contact information.



Press **Nav** or **ESC** to exit the **Contact view** and return to the **C Address main screen**.

---

## Edit a contact

You can edit a contact by selecting it in the contact list and then select **Edit** in the **Contact menu**.

This will open the **Contact edit screen**, displaying all the stored information. You can move between fields by turning **Nav**. If you want to change the contents of a field, you can read a new field text with C-Pen or edit the text in the usual way, see **Editing text**, p. 33.

## Find a contact

To find a contact, navigate to the **C Address main screen** and select **Find**. The **Find contact screen** will open.

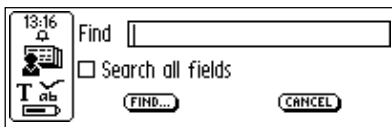

*Find  
contact screen*

Enter the search text either by using **C Write**, or insert characters from the character set. To start searching **C Address**, select the **FIND** button. The **Find contact screen** closes and a contact list containing the contacts with matching information will be displayed. You can select these files, just as you do in the contact list.

If the **Search all fields** check box is checked, *all* information stored in **C Address** will be searched in order to find matching text.



If the **Search all fields** check box is not checked only names will be searched, (**First name**, **Last name** and **Full name**).



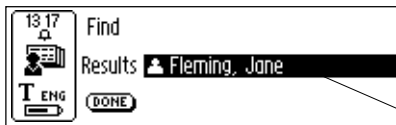

*Search result*

Select **DONE** to close the screen and return to the **C Address main screen**.

If no matching text is found, a dialog box with the message “Nothing found” appears. Select **OK** to go back to the **Find contact screen**.

### **Delete a contact**

Select a contact in the contact list and select **Delete**. A dialog box will ask you if you are sure that you want to delete the contact. Select **YES**. The contact is now deleted.

### **Exit C Address**

You can exit **C Address** from the **C Address main screen** by selecting **Exit** or by pressing **ESC**.

---

## C Calendar

### Introduction

**C Calendar** is an application which works like a normal calendar, but with the advantage that you can display your events and tasks in many different ways once you have the information in your C-Pen. You can choose to view a whole month, a single week or a day, and you can either read or write the information into your C-Pen.

### Using C Calendar

Start **C Calendar** by highlighting the **C Calendar** icon in the C-Pen **main screen** and pressing Nav.



*C-Pen  
main screen*

The information is displayed in the **Day view**, **Week view**, **Month view** or the **Task list**, see p. 66. You can choose to change to another view or you can either look at or edit the stored events/tasks. You change view with the **View buttons**, see below.

### View buttons

On the left-hand side of the bottom line of the display are three buttons. The buttons change depending on where you are in **C Calendar** and they change between the following four alternatives:

---

- **Day button**

The button with number 1 in the display. When the **Day button** is pressed the **Day view** appears, see p. 62.

- **Week button**

The button with number 7 in the display. When the **Week button** is pressed the **Week view** appears, see p. 62.

- **Month button**

The button with number 31 in the display. When the **Month button** is pressed the **Month view** appears, see p. 63.

- **Task button**

The button with a check mark in the display. When the **Task button** is pressed the **Task list**, see p. 67, is opened.



*Day, week, month and task button*

When a view has been chosen the cursor automatically highlights the **Menu button**.



*Menu button*

## **Menu button**

Selecting the **Menu button** opens the **C Calendar main menu**.

In the menu you can choose between the alternatives listed below. *Please note* that the alternatives **New...**, **Select...** and **Go to month/week/date** depend on whether you are in the **Task list**, **day**, **week** or **month view**, see below.



*C Calendar  
main menu*

- ! In **C Calendar** you will always find the scroll bar on the right-hand side of the display.

Pressing the **Menu button** opens the **C Calendar main menu** with the following alternatives:

- **Exit**

Closes **C Calendar** and returns to the **C-Pen main screen**.

- **New...**

Opens a new event/task in the **Event edit screen/Task edit screen**.

- **Select week**

Enables the selection of a whole week at a time in the **Month view**. When a week is highlighted and **Nav** is pressed, the chosen week's **Week view** will be displayed.

- **Select day**

Enables selection of a day in the current **Week view**. When a day is highlighted and **Nav** is pressed, the selected day is opened in the **Day view**.

- **Select event**

Enables selection of one of the listed events in the current **Day view**. When an event is highlighted and **Nav** is pressed, all the event details are displayed. See the **Details screen**, p. 68.

---

- **Select task**

Enables selection of one task in the currently displayed **Task list**. When a task is highlighted and **Nav** is pressed, all the task details are displayed. See the **Details screen**, p. 68.

- **Find...**

Opens the **Find dialog box**. See **Finding an event**, p. 69.

- **Go to date/week/month...**

Opens a dialog box in which you can enter a particular month, week or date. As default the present month/week/date is selected.

- **Settings...**

Shows the settings and enables you to edit them.

- **Cancel**

Closes the **C Calendar main menu**.

## **Back/Forward button**

On the right-hand side of the bottom line of the display are two arrow buttons which are called the **Back/Forward buttons**.



The right-arrow button is the **Forward button** and changes the date forwards in time, while the left-arrow button, the **Back button**, changes the date backwards.

If you want to change a date a long time ahead of the present date you can press the **Menu button** and then select the option **Go to day/week/month...** in the **C Calendar Main menu**, p. 60

---

## Day view

The **Day view** is reached by clicking the **Day button**, see p. 59, on the bottom line of the display.

When you are in the **Day view** another day can be viewed by clicking the **Back/Forward buttons** on the bottom line, see above.

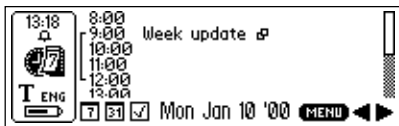

*Day view*

The **Day view** is used to view all events during one particular day and the title of the event is given to the right of the starting time. Depending on the chosen event alternatives (repetition, note and alarm), different icons will be shown to the right of the event title.

Brackets are used to show the event's length and possible overlap with other events.

## Week view

The **Week view** displays a single week at a time and the screen is reached by selecting the **Week button**, see p. 62, on the bottom line of the display.

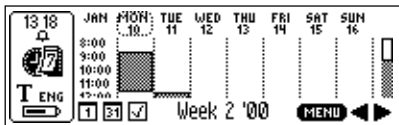

*Week view*

Another week can be viewed by clicking the **Back/Forward buttons** on the bottom line, see p. 61.

The **Week view** is used to view all events during one particular week and the events are shown as shaded boxes. The size of the box corresponds to the length of the event and the position corresponds to the starting time.

If the current date is in the chosen week, it is marked with a circle around the date, see the figure above.

## Month view

The **Month view** displays a single month at a time. The screen is reached by selecting the **Month button** on the bottom line of the display, see p. 59.



*Month view*

The previous/next months can be viewed by clicking the **Back/Forward buttons** on the bottom line, see p. 61.

The **Month view** is used to view all events during a month and the events are shown as small boxes to the right of the date. The size of the boxes corresponds to the length of the event and the position corresponds to the starting time.

When viewing the current month the current date is highlighted, see the figure above.

## Creating an event

A new event can be created in two different ways: press the **Menu button**, see p. 59, when you are in the **Day, Week** or **Month view** and select **New...**, then read text directly with C-Pen or enter edit mode and write the text into the edit

---

fields with **C Write**. You can also read directly with C-Pen when you are in a **Day, Week** or **Month view**. The scanned text will automatically be placed in the title edit field of a new event in the **Event edit screen**, see below.

## Event edit screen

The **Event edit screen** is opened by pressing the **Menu button** when you are in the **Day, Week** or **Month view** and then selecting **New....** It can also be opened from the **Details screen**, see p. 68, by selecting **Edit....** In both cases you can edit all fields on the screen.

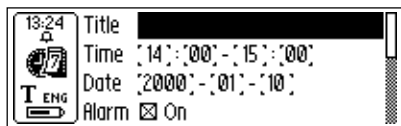

*Event edit screen*

You can either read an event title directly into the first edit field, **Title**, or you can enter edit mode by pressing **Nav** and then use **C Write**. The same goes for the edit field called Note in which you can enter the event details.

The next option is reached by turning **Nav**.

The time and date are changed by highlighting the first set of figures (in Date this will be the year), then pressing **Nav** and turning it to the required value. When you are done, press **Nav** and you will automatically enter the next set of figures (in Date this will be the number of the month) where you can turn **Nav** to change the value. The check boxes are checked/unchecked by pressing **Nav**.

If a repeating event is shown in the **Details screen** and you press the **Menu button** and select **Edit....**, two optional check



---

boxes are displayed. You can choose to edit the event only for the *current day* or for an *interval* between dates. If an interval is chosen, default is set to the full interval, but can be changed if you want to. Clicking **OK** will open the chosen event for editing.

To save your changes, click **OK**. Click **CANCEL** to discard all changes. After clicking **OK/CANCEL** C-Pen automatically returns to the previous screen. For further information about the event options and the **Repeat button** see **Event options** below.

### **Event options**

The **Event edit screen**, see p. 64, contains the following options:

- **Title**

Event title. You can either read directly into the edit field or enter **C Write** and write the text. Maximum length of the text string is 60 characters.

- **Time**

Starting and finishing time in hours and minutes. As default the starting time is set to at least one hour from the present.

- **Date**

Starting date of the event. Year, month and day can be set. As default the last viewed date in the **Day View** is set as the starting date.

---

## • Alarm

Check/uncheck an audio reminder of an event. The time can be set up to one hour before the event. The alarm is independent of whether or not C-Pen is turned on or off.

! **Please note** that the alarm check box is only available if the starting time is *ahead* of the present date and time.

## • Note

Further notes concerning an event can be placed in this field, either by reading text or by entering **C Write** and writing the text.

## • Repeat

Events can be set to be repeated at certain intervals, see **Repeat check boxes** below. Pressing the **Repeat button** opens a dialog box in which you can set the interval of repetition as well as the finishing date.

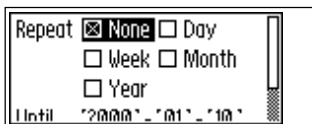

*Repeat dialog box*

The **Repeat check boxes** are:

### • Day

Every day

### • Week

The same day every week

### • Month

The same date every month

---

## • Year

The same date every year

## Creating a task

A new task can be created in two different ways: press the **Menu Button**, see p. 59 when you are in the **Task list**, see below, and select **New...**, then read text directly with C-Pen or enter edit mode and write the text into the edit fields with **C Write**. You can also read directly with C-Pen when you are in the **Task list**. The scanned text will automatically be placed in the title field of a new event in the **Task edit screen**, see below.

## Task list

When the **Task view button** is pressed the **Task list** is opened and all the tasks in the calendar are displayed in the order in which they were entered in **C Calendar**.

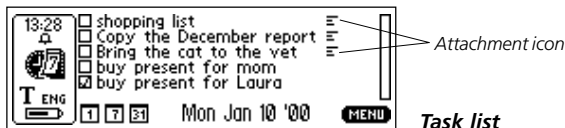

The tasks are shown with their title and their status, i.e. checked or unchecked. The **Attachment icon** is shown beside a task if there are further notes belonging to the task. Tasks are checked/unchecked in the **Details screen**, see p.68.

---

## Task edit screen

The **Task edit screen** is opened from the **Task list** in two different ways: press the **Menu button** and select the option **Select task** in the menu. Press **Nav** when the required task is highlighted and the **Task edit screen** opens. You can also start reading text when you are in the **Task list**. This will open the **Task edit screen** and the scanned text will be placed in the first edit field (Title).

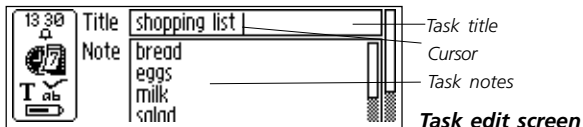

Pressing **OK** will save the task and the updated **Task list** will then automatically be displayed. Pressing **Cancel** will discard all changes made to the event.

## Details screen

The **Details screen** can be opened both for events and for tasks. Press the **Menu button** in the **Day view** and choose **Select event**, then highlight an event and press **Nav** to open the **Details screen** for an event.

If you want to view the details of a task, press the **Menu button** when you are in the **Task list** and choose **Select task**. Then highlight a task and press **Nav** to open the **Details screen** for a task.

All information on the selected event/task will be displayed on the screen.

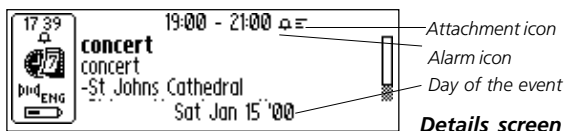

When pressing **Nav** a menu appears with the alternatives **Done**, **Check**, **Edit...**, **Delete...** and **Cancel**. Pressing **Cancel** will take you to the previous screen.

A task can be checked/unchecked in the **Details screen** by pressing **Nav** and then selecting **Check/Uncheck** in the menu.

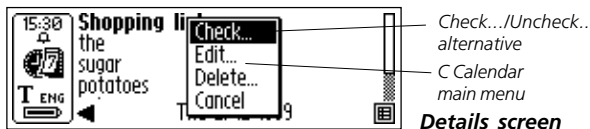

## Deleting an event or a task

You can delete an event or task when viewing it on the **Details screen**, by selecting **Delete...** in the **C Calendar Main menu**.

## Finding an event

The **Menu button** contains the option **Find...**, which is used to find a text string among all the stored events. The text string to be found can be read or written into the edit field. You can also decide if your search is to be *case sensitive* or not.

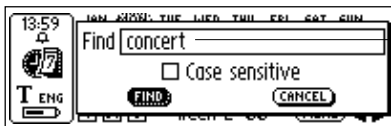

Text string

*Find dialog box*

If events are found containing the text string, they will be displayed on the screen.

## Settings...

By pressing the **Menu** button and choosing **Settings...**, the list of settings in **C Calendar** is opened.

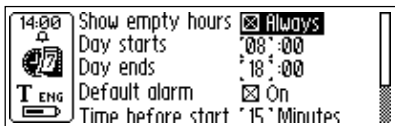

*Options in Settings...*

The setting options are:

- **Show empty hours**

Determines whether free hours, i.e. no event is booked, should be displayed in the **Day view**.

- **Day starts**

Defines at what time the default day starts, which effects the different views. The default day will be shown from the starting time unless there are events entered before that time.

- **Day ends**

Defines at what time the default day ends, this has similar effect to the setting **Day starts**, see above.

---

- **Default alarm**

Enables/disables default alarm for all new events.

- **Time before start**

Functions together with the **Default alarm** setting to enable an audio alarm for events at a specified time before the starting time.

- **Use large fonts**

Enables the use of large fonts whenever this is possible in **C Calendar**.

## **Exit C Calendar**

Exit **C Calendar** by selecting **Exit** in the **C Calendar Main menu**, or by pressing **ESC** a few times in order to go to the **C-Pen main screen**.

---

## C Dictionary

### Introduction

**C Dictionary** is a software application that allows you to translate and/or look up definitions of words in less than a second. Whether you translate or look up definitions depends upon which dictionary you choose to install. With bilingual dictionaries, you can translate from one language to another. Some dictionaries are monolingual reference dictionaries and can only look up definitions of words.

C Dictionary translates or looks up words one word at a time, the same way you would look up words in a paper dictionary. You can however, scan in an entire line of text and then choose which word you wish to look up.

Several kinds of dictionaries are available from a variety of publishers. The dictionaries available for download are copyrighted by their respective publisher. See **Copyright Notice** for details, p. 123.

Before you start installing the dictionaries, make sure you have a working connection between C-Pen and your PC. See **Using C-Pen with your PC**, p. 107.

### Installing a dictionary from the C-Pen CD

Follow the steps below to install a Dictionary.

1. The dictionaries are available in the Start menu/Programs/C-Pen/Dictionaries. Select the dictionary you want. Make sure you have your C-Pen CD in your CD-ROM drive.



---

! **Please note** that dictionaries not available on the CD at the time of going to press will be available on [www.cdictionary.com](http://www.cdictionary.com) as soon as they are made available.

2. You can now see the C Dictionary Installer view. Make sure the dictionaries you want are selected.
3. Start your C-Pen, position C-Pen so that it is aligned with the PC's IR port or ensure that the cable is connected, then press Start.
4. The dictionary will now be transferred to your C-Pen. This can take some time, so please be patient. The number of dictionaries that can be installed in C-Pen depends on the amount of free memory in your C-Pen, see **Info**, p. 97.

### **Installing a dictionary from the web**

1. Download the dictionary you want from our web site [www.cdictionary.com](http://www.cdictionary.com).
2. Click on the file, and an automatic installation program will start.
3. You can now see the C Dictionary Installer view. Make sure the dictionaries you want are selected.
4. Start your C-Pen, position C-Pen so that it is aligned with the PC's IR port or ensure that the cable is connected, then press Start.
5. The dictionary will now be transferred to your C-Pen. This can take some time, so please be patient. The number of dictionaries that can be installed in C-Pen depends on the amount of free memory in your C-Pen.

---

## Access to dictionaries

Dictionaries are protected from unauthorized use by a dictionary license key. For more information about how to obtain the license key, see [www.cdictionary.com](http://www.cdictionary.com).

The user is requested to provide the license key to activate a new dictionary in C-Pen (the **DICTIONARIES** button in the C Dictionary application). The Enter License Key dialog box contains six number boxes. Enter the numbers one by one using **Nav**.

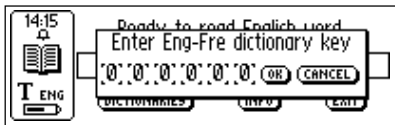

*Enter  
dictionary key*

If you enter the wrong license key four times in a row, the dictionary will be removed. To try again, you must reinstall the dictionary, see **Installing...** above. Once the correct license key is entered, the dictionary is ready to use.

! *Please make sure* that you have the license key before you upgrade your C-Pen or remove a dictionary. To find your license key, select the info button on the C Dictionary main screen in your C-Pen.

## Removing a dictionary

To remove a dictionary from C-Pen, double-click on the My C-Pen icon on your PC, select C Dictionary and then the dictionary you want to delete. Use the Delete command in the File menu. You have to use your PC to remove a dictionary from C-Pen.

! **Please make sure** that you have the license key before you delete a dictionary.

## Using C Dictionary

Start **C Dictionary** by selecting the **C Dictionary** icon in the **main screen** and press **Nav**.

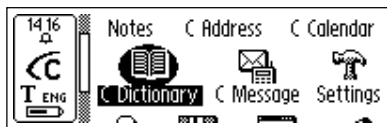

**C-Pen**  
**main screen**

C-Pen is now ready to translate/look up words. If you want to change dictionaries before you start reading, see **DICTIONARIES button**, p. 80.

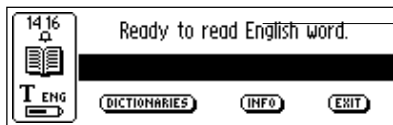

*The language from which you want to translate*

*Word edit box*

**C Dictionary**  
**main screen**

To translate/look up a word, just read the word with C-Pen as usual. One of the following events will occur:

1. The word is found in the dictionary and the translation/definition is presented on the screen, see **Translation/definition screen** p. 77.
2. No exact match of the word is found in the dictionary, a list of alternatives is displayed, see **Word selection list**, p. 78.
3. Several words are read. The words are shown on a new screen where you can select the words to be translated/looked up, see **Word selection screen**, p. 79.

- 
4. A dialog box appears, telling you that the word cannot be found in the dictionary.

When you are reading a word, the word (or part of the word) in front of and/or behind the accurate word might also be included. If this is the case **C Dictionary** acts according to the following rules:

- If two words are read, the longest word is translated.
- If three words are read, the middle word is translated.
- If more than three words are read, the **Word selection screen** is displayed, see next page.

### **Word edit box**

The word/s you have read are directed to an edit box where you can edit them in the usual way.

1. To be able to edit the word/s you have to close the dialog boxes, lists or screens that might have been opened after reading.
2. The edit box will already be selected. Press **Nav** and a cursor will indicate that you are in edit mode.
3. Press **Nav** again to open the **Edit menu** or use **C Write** to edit the word.
4. When you have finished editing, select **Done** in the **Edit menu** or press **ESC**.
5. The edited word will now be looked up in the dictionary.

---

## Word references

Some words in the dictionaries contain references to other words. The references are displayed in ***bold italic*** style.

If you press **Nav** when a word reference is displayed, a menu appears and you can choose to:

- look up the reference
- cancel the menu
- close the translation/definition containing the reference

If you choose to look up the reference, the word will be translated.

## Translation/definition screen

The **Translation/definition screen** displays the translation of the selected word. If only part of the text will fit on the display a scroll bar will appear. Turn **Nav** to scroll the text.

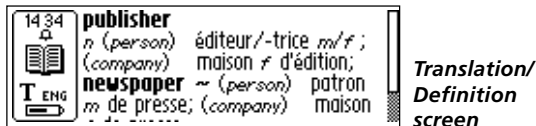

The meaning of bold and italic characters is explained in **Info**, see **Info button** p. 80.

To cancel the scanned word/text and go back to the **C Dictionary main screen**, press the pen tip briefly against the surface (for a C-Pen with an automatic trigger) or press **Trigg** briefly (for a C-Pen with a manual trigger).

---

A new word can be read without closing the screen. Close the **Translation screen** by pressing **Nav** or **ESC**.

## Word selection list

If the word being read does not match any word in the dictionary, the application will search for similar words and display alternatives in a **Word selection list**.

The most probable word is presented at the top of the list with the others in descending order of probability. A maximum of ten words will be displayed. Select a word to see the translation/definition.

The reason why a word cannot be found may be that the word is misspelled or that the OCR has given an erroneous result. Another reason can be that the word is inflected (e.g. chairs instead of chair).

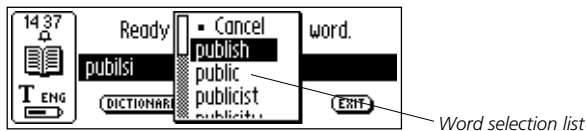

A **Word selection list** will be displayed if more than one word is found with the same spelling as the word being read, but with different meanings.

To cancel the word/text scanned and go back to the **C Dictionary main screen**, press the pen tip briefly against the surface (for a C-Pen with an automatic trigger) or press **Trigg** briefly (for a C-Pen with a manual trigger).

You can start to read a new word without closing the list. Close the **Word selection list** by selecting **Cancel** or by pressing the **ESC** button.

---

## Word selection screen

If more than three words are read the **Word selection screen** appears. Turn **Nav** to select a word.

The selected word is looked up and the **Translation/definition screen**, **Word selection list** or **Can't find** dialog box will be displayed.

To cancel the scanned word/text and go back to the **C Dictionary main screen**, press the pen tip briefly against the surface (for a C-Pen with an automatic trigger) or press **Trigg** briefly (for a C-Pen with a manual trigger).

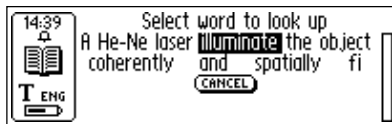

*Word selection screen*

You can start to read a new word without closing the screen. Close the **Word selection screen** by pressing **ESC** or by selecting the **CANCEL** button.

## Text Language

The **Text Language** is automatically set to the language you are translating from; i.e. German is set for the German-English dictionary. Exiting **C Dictionary** will restore the **Text Language** to the language that was set before entering **C Dictionary**.

---

## Dictionaries button

The **DICTIONARIES** button in **C Dictionary**'s main screen is shown below.

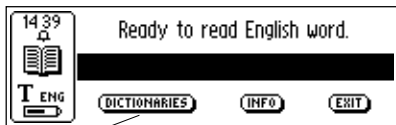

*C Dictionary  
main screen*

*Dictionaries button*

The **DICTIONARIES** button gives you access to the **list of dictionaries** in your C-Pen. Select the dictionary you want to use by checking its check box, and then select **OK**.

- ! If you want to use the same dictionary the next time you use your C-Pen you do not have to repeat this procedure, since the dictionary setting is stored when C-Pen is turned off.

## Info button

The **INFO** button displays information about the currently selected dictionary, the number of words, the publisher of the dictionary and copyright information. Your dictionary license key is also shown here.

- ! Before you upgrade your C-Pen or delete a dictionary, make sure you have recorded the license key.

## Exit C Dictionary

You can exit **C Dictionary** from the **C Dictionary main screen** by selecting **EXIT**, or press **ESC** a few times until you are back in **C-Pen main screen**.



---

## C Message

### Introduction

**C Message** is an application for sending faxes to a fax machine, text messages, SMS, to a mobile phone or e-mails to an e-mail address. Text messages can only be sent in combination with a mobile phone. **C Message** consists of **C Fax** and **C SMS**.

- ! *Please note* that **C Fax** and **C SMS** require a mobile phone equipped with an IR eye and a fax modem. For more information please refer to our webpage: [www.cpen.com](http://www.cpen.com).

You can send complete files from **Notes** or write a short message with **C Write** into **C Message** and then send it. The SMS standard limits the messages sent with **C SMS** to a length of 160 characters. Fax messages are not limited.

- ! **SMS** (Short Message Service) is available for mobile phones using the GSM system. There is limited access to this service in several parts of the world. Contact your mobile phone service provider for information on availability in your area.

### Using C Message

There are two ways to send a message, either from **C Message** or from **Notes**. If you want to send a text which is not stored in **Notes**, you can select the **C Message** icon in the C-Pen **main screen**.

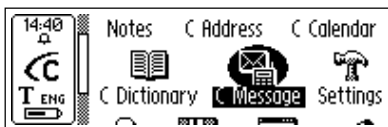

*C-Pen  
main screen*

The **C Message main screen** is opened and you can now send a fax or an SMS by selecting **C Fax** or **C SMS**.



*C Message  
main screen*

In order to send a text file stored in **Notes** you have to open **Notes**, select the file and in the menu that appears select **Send**. A new menu containing the **C Message** options will open and you can choose the desired alternative.

### **C Fax main screen**

The **C Fax main screen** opens when **C Fax** is selected.



*C Fax  
main screen*

The options in the **C Fax main screen** are:

- **Exit**

Exits **C Fax** and returns to **C Message main screen**.

- **New fax...**

Opens the **Contact list** from which you can select to whom the message is to be sent, see p. 84.

---

- **Settings**

Settings options for **C Fax**.

- **Sent**

Successfully sent fax messages are stored in this folder.

- **Unsent**

Unsent fax messages, due to transmission error or the user selecting **CANCEL**, are stored in this folder.

! *Please note* that only the contacts listed with a fax number will be shown in the **Contact list**. If the recipient is not listed, select **NEW...** and enter the contact information in the **Message setup screen**, see p. 85.

## **C SMS main screen**

The **C SMS main screen** opens when **C SMS** is chosen.



***C SMS**  
main screen*

The options in the **C SMS main screen** are:

- **Exit**

Exits **C SMS** and returns to **C Message main screen**.

- **New SMS...**

Opens the **Contact list**, see below.

- **New SMS-Email...**

Opens the **Contact list**, see below.

---

- **Sent**

The folder where successfully sent SMS messages are stored.

- **Unsent**

The folder where unsent SMS messages, due to transmission error or the user selecting **CANCEL**, are stored.

! *Please note* that only the contacts listed with a mobile phone number (for SMS messages) or an e-mail address (for e-mail) will be shown in the **Contact list**. If the recipient is not listed, select **NEW...** and enter the contact information in the **Message setup screen**, see below.

## Contact list

The **Contact list** is opened when you select **New fax...**, **New SMS...** or **New SMS-Email...**

The contacts listed in your address book, **C Address**, are shown and you can select a contact by checking its checkbox. If you want to send a message to a person not listed in your address book you can select **NEW...** and read/write the information directly into the **Message setup screen**.

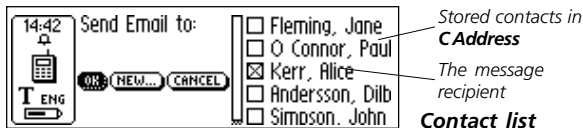

To add the new contact information to your address book, click the **ADD TO C ADDRESS** button at the bottom of the **Message setup screen**, see below. If there are no contacts

---

listed with e-mail/fax/SMS numbers, the **Contact list** will not be displayed. Instead the **Message setup screen**, see below, will appear.

## Message setup screen

The **Message setup screen** is opened when you select either **OK** or **NEW...** in the **Contact list**, see above.

The buttons in the **Message setup screen** are:

- **ADD TO C ADDRESS**

Stores the new information as a new contact in your address book in **C Address**.

- **SEND**

Sends the message if the connection to the mobile phone is OK. A sent message is stored in the **Sent** folder. If the connection failed the message is stored in the **Unsent** folder.

- **CANCEL**

Cancels the **Message setup screen** and returns to the previous screen. The message is stored in the **Unsent** folder.

There are different options depending on whether a fax, SMS or SMS-e-mail is to be sent.

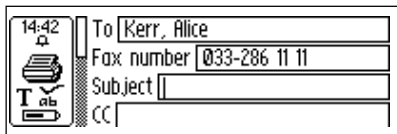

The screenshot shows a mobile phone interface for setting up a message. On the left, there is a status bar with the time 14:42, a bell icon, a printer icon, a 'T' icon, and a battery icon. The main area contains four input fields: 'To' with the text 'Kerr, Alice', 'Fax number' with the text '033-286 11 11', 'Subject' which is empty, and 'CC' which is also empty.

*Message setup*

---

The **fax options** are:

- **To**

The name of the recipient.

- **Fax number**

The recipient's fax number.

- **Subject**

Message subject.

- **CC**

Name/e-mail address of other person/persons you want to send a copy of the message to.

- **From**

The name of the sender/user.

- **Message**

The message to be sent.

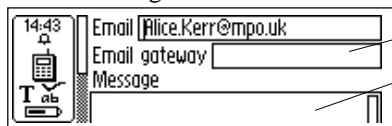

*This number is given by your mobile phone retailer.*

*Message text field*

**Message set up screen (SMS-Email)**

The **C SMS/SMS-Email** options are:

- **Mobile phone number**

The recipient's mobile phone number, needed for SMS messages.

- **Email**

The recipient's e-mail address, needed for SMS-Email.

- **Email gateway**

E-mail gateway, needed for SMS-Email. This is given to you by your cellular phone operator.

---

- **Message**

The message to be sent.

All fields can be edited either by reading text or by writing text with **C Write**.

If **OK** was selected in the **Contact list** the chosen contact's name and number are automatically entered in the **Message setup screen**.

If **Send** was selected from **Notes** you will find the contents of the selected file in the **Message** text field in the **Message setup screen**.

## Settings

There is a **Settings menu** for the fax page setup and it is reached from the **C Fax main screen**.



*C Fax  
Settings menu*

The **Settings menu** contains the following options:

- **Sender info**

Information about the sender, such as name and company. This information will be inserted on all fax pages once it has been entered. This information is stored in the C-Pen memory and has to be entered only once.

- **Logotype**

A list of stored logotypes, from which you can select the one you want to put on your fax page. See below.

---

- **Footer**

A list of stored footer images, from which you can select the one you want to put on your fax page. See below.

- **Resolution**

The resolution of the fax page, with the options **Normal** (low resolution) and **Fine** (high resolution).

- ! *Please note* that transmission of fine resolution fax pages is more time consuming.

- **Cancel**

Cancels the **Settings menu** and returns to the **C Fax main screen**.

## Download logotypes and footers

If you have logotypes and/or footers you want to add to your C-Pen fax pages, you can download them from your PC to your C-Pen.

Establish a connection between your C-Pen and your PC. Open **C-Pen viewer** and copy the image files from your PC and paste them in the **C Fax Logos** folder in **Storage**, see p. 98. You can also drag the file from the PC folder and drop it onto the **C Fax Logos** folder in **Storage**.



**C Fax Logos**  
folder in **Storage**

- ! *Please note* that the image files must be uncompressed and in black-and-white BMP format.



---

## Settings

**Settings** contains the parameters that control C-Pen. Enter **Settings** from the **Main screen** by selecting the **Settings** icon. You can also enter text settings from the **Text menu**, p. 50 and the **Edit menu**, p. 33. A list of the available settings appears.

The following settings are available:

- Text Language
- Read Mode
- Text Quality
- C Write Feedback
- Calibration
- System Settings

**Text Language**, **Read Mode** and **Text Quality** are referred to as **text settings**. You should set up these settings to achieve optimal OCR.

To modify a setting:

1. Turn **Nav** to highlight the setting you want to change. Press **Nav** and a check box or menu appears.
2. Turn **Nav** to highlight the option you want and press **Nav** to select the chosen value.
3. Select **OK** to close the dialog box and save the changed setting.
4. Exit **Settings** by selecting **Exit** at the top of the **Settings** menu, or alternatively press **ESC**.

---

## Text Language

Select the language of the text you want to read from the list of languages, by checking the check box. If you only intend to read numbers, select **Numbers Only** as the language.

## Read Mode

**Read Mode** adjusts C-Pen's reading format. The options are:

- **Continuous**

A space is inserted between two separate readings with the C-Pen. Suitable when you read a complete paragraph which will be used in a document on your PC.

- **Separate lines**

Each reading starts on a new line.

- **Tab**

Each reading starts after a tab.

## Text Quality

Use this setting to indicate if the printed text is normal or inverted (negative).

- **Normal**

Black text on white background.

- **Inverted (negative)**

White text on black background.

## C Write Feedback

Check the check box if you want to enable/disable the visual feedback facility in **C Write**.

---

## Calibration

The **Calibration** option increases C-Pen's reading ability if the text is not black, if the background is not white, or if the text quality is poor. During the calibration process, C-Pen will find the appropriate balance of black and white for the particular surface. If your C-Pen reads poorly, try to calibrate it. However, the default settings should be able to cope with most cases.

Calibration overrides the factory settings. The calibrated setting is not saved when C-Pen is turned off. If you want to revert to the factory setting without turning C-Pen off, select **Calibration** in **Settings** and then **Calibrate**. Select **DEFAULT SETTING** in the dialog box.

Inverted (negative) text must be reset in **Text Quality**.



*Please note* that it is impossible to read red text.

If calibration does not improve the reading accuracy, return to the default setting.



The **Calibration menu** contains three items:

1. **Calibrate**, where you can :

**Calibrate** immediately by moving the pen over the text surface, see **How to...** p. 92 and 93, or return to the **DEFAULT SETTING** which is the factory setting.

- 
2. **Options**, where you can enable/disable the **Quick Calibration** option.

**Quick calibration** is the preferred option if you often read texts with very different text contrasts. **Quick calibration** is disabled as default.

**Quick calibration** enables C-Pen to start a calibration as soon as you press **Trigg**.

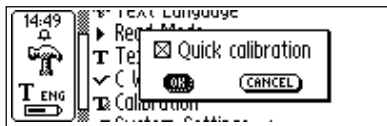

For a C-Pen with a manual trigger, the pen tip should be pressed flat against the surface and held, perfectly still, while you press **Trigg** for about two seconds.

For a C-Pen with an automatic trigger the pen tip should be pressed flat against the surface and held, perfectly still, for about two seconds.

3. **Cancel**, returns to the main menu.

### **How to Calibrate a C-Pen with a manual trigger**

**Calibrate** adjusts C-Pen's reading ability according to the contrast between the text and its background. When the C-Pen display says "*Press scan to calibrate*", follow these instructions:

1. Hold C-Pen with the pen tip flat against the surface.
2. Press **Trigg** while moving the pen. If calibration is performed from a menu other than the **Settings main**

---

**menu**, you should press **Trigg**, hold the pen still for two seconds and then move it over the surface.

3. A progress indicator appears on C-Pen's screen.

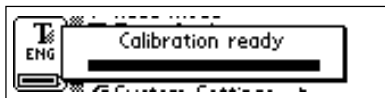

4. Move C-Pen over the text, in circles or back and forth. Continue to move C-Pen until the progress bar is complete.
5. A message indicates that calibration has been completed.

When your C-Pen is calibrated the **Text Quality** icon in the status field changes appearance.



*Text Quality icon*

### **How to Calibrate a C-Pen with an automatic trigger**

When C-Pen instructs you to calibrate, follow these instructions:

1. Hold C-Pen with the pen tip flat against the surface. If calibration is performed from a menu other than the **Settings main menu**, you should first hold the pen still for two seconds and then move it over the surface.

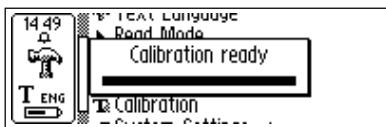

2. A progress indicator appears on C-Pen's screen.
3. Move C-Pen over the text, in circles or back and forth. Continue to move C-Pen until the progress bar is complete.
4. A message indicates that calibration has been completed:

When your C-Pen is calibrated the **Text Quality** icon in the status field changes appearance.



*Text Quality icon*

## System Settings

To see which of the following settings that are available with your C-Pen see C-Pen Models, p. 6-7.

### • PIN code

You can control access to your C-Pen by a four-digit PIN code. Enter the PIN code setting to enable or disable your PIN (Personal Identification Number).

When the dialog box opens, the zero in the first position will blink. Turn **Nav** to select the first digit of your PIN. Then press **Nav** to go the next position. Continue with

---

all four digits. When you have reached **OK**, press **Nav** and confirm the PIN in a new dialog box.

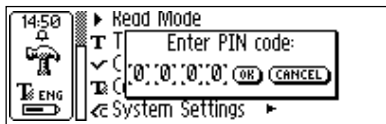

If a PIN code is enabled, you must enter the PIN each time C-Pen is turned on. After three unsuccessful attempts, C-Pen will turn off. You get three attempts each time you start C-Pen.

**Warning!** If you start C-Pen by selecting **DISABLE PIN CODE** in the start up dialog box, all data in C-Pen will be lost! You can change or disable your PIN code by selecting **PIN code** in **System Settings**.

*Please* remember to write down your PIN code and keep it in a safe place, in case you forget the code!

- **Contrast**

Display contrast. Select the bar and turn **Nav** to change the display contrast.

- **Time**

The time shown in the status field can be set according to your preferences.

- **Sound**

**Alarm sound** and a **System sound** which can be switched on/off. The **System sound** is activated in combination with certain message dialog boxes.

---

- **Menu Language**

The language that C-Pen uses in its menus and dialog boxes. Select the desired menu language in the list of check boxes.

- **Font**

The font size on C-Pen's display can be altered between **Large** (default) and **Small**. Depending on the C-Pen model **Large** gives a 2-5 row display and **Small** gives a 4-7 row display.

- **Power-off time**

The duration of inactivity in minutes before C-Pen turns off automatically.

- **Left/Right Hand**

A Left/Right-handed option. Check **Left** or **Right** to orientate the text on the display for left- or right-handed use. Select **OK** and press **Nav**.

- **Exchange Trigger/ESC**

For a C-Pen with a manual trigger, the option to exchange the functions of **Trigg** and **ESC**. Checked box means normal use, see **Parts of C-Pen**, p. 14.

- **Autotrigger**

For a C-Pen with an automatic trigger, the Autotrigger is enabled by default. The **Autotrigger** can be switched off and you will then have to press the **ESC** button in order to read text. The **ESC** button will become the **Trigger (Trigg)** and there will be no **ESC** button.



---

## Info

**Info** contains a list of help and information topics. Press **Nav** or **ESC** to close the topic. The topics are:

- **Exit**

Exits **Info**.

- **Getting started**

Instructions on how to perform a successful reading.

- **Troubleshooting**

Solutions to common problems.

- **Support**

Support addresses to C Technologies.

- **About C-Pen**

Contains OS (Operating System) version numbers and serial number. You should have these numbers available when you contact C Technologies for support.

The amount of free memory space is also given. If the scroll bar is present, select it and turn **Nav** to scroll through the information. To close the topic, deactivate the scroll bar by pressing **Nav** or **ESC**, then select **OK** or press **ESC**.

---

## Storage

**Storage** is a storage area for computer files, that can be used as a floppy disk. Storage contains the folder C Fax Logos, see p. 88, which is used when sending fax messages, see **C Message**.

Selecting a file in **Storage** opens a menu with the following menu items:

- **Open**

Opens the selected file.

- **Delete**

Removes the selected file.

- **Properties**

Displays the selected file size, creation date and date of last modification.

- **Beam**

Transfers the selected file by IR, see p. 100.

- **Cancel**

Cancels the menu.

To be able to use **Storage**, C-Pen must be connected to a PC and C Win Software must be installed. See **Using C-Pen with your PC**, p. 107.

To start **Storage**, you must connect your C-Pen to your PC by double-clicking the My C-Pen icon on your PC. **Storage** is started by double-clicking the Storage icon in C-Pen Viewer on your PC. Files which can be edited in C-Pen Edit (e.g. filename.txt) are opened by double-clicking the files. Other file types can be opened in two ways.

---

**Copy** the file to a temporary folder on your PC and then open it with its default Windows application.

**Double-click** the file and you will be asked if you want to open a copy instead. Choose to open a copy.

In these cases, if you edit the file and save it, your changes will be saved on your PC, not in your C-Pen.

Files are copied as usual in Windows, i.e. either by using drag-and-drop or Copy/Paste in the Edit menu. See **Copy and Paste in the PC environment**, p. 110.

You can delete files in **Storage** by selecting the file/files you wish to delete and then pressing the Delete button on your keyboard. The Delete command is also available in the File menu. Please note that this operation cannot be undone.

---

## C Beam

**C Beam** is used to transfer notes, contacts, calendar events and other files between C-Pen and PDAs (Personal Digital Assistant). **C Beam** supports the standard infrared protocol IrOBEX and complies with both the vCard and vCalendar standards.

- ! *Please note* that the PDA device must support the standard infrared protocol **IrOBEX** in order to be used with C-Pen.

If you should experience problems with **C Beam**, start by turning off and on both C-Pen and the PDA device.

### Receiving files

In order to receive information files from a PDA device with your C-Pen, follow the steps below.

1. Make sure that the C-Pen's IR-eye is directed towards the PDA device's IR-eye.

- ! *Please note* that it is very important that the IR-eyes are aligned and in range of each other (5-20 centimeters, or 2-8 inches). There must be no obstacles between the devices.

2. Send the file from the PDA device according to the instructions in the PDA's user manual.
3. The IR-symbol in C-Pen's status field indicates activity. The **Receive dialog box** appears on the screen, displaying the name of the transferred file.
4. You can cancel the transmission at any time by pressing **CANCEL** in the **Receive dialog box**.

- 
5. After transmission the **Accept dialog box** is displayed, asking if you want to accept the transferred file.
  6. If you press **YES** the file will be saved in the appropriate place, i.e. a text file is saved in **Notes**, a contact file is saved in **C Address**, a calendar event is saved in **C Calendar** and so on. Files not compatible with any of the C-Pen applications are saved in **Storage**.

If you press **NO**, C-Pen will discard the received file and no further action will be taken. You must repeat the transmission if you press **NO** by mistake.

! **Please note** that in order to receive several files you must answer either **YES** or **NO** in the **Accept dialog box** after every transferred file.

## Send files

To send information files from your C-Pen to a PDA device, follow the steps below.

1. Make sure that the C-Pen's IR-eye is directed towards the PDA device's IR-eye.

! **Please note** that it is very important that the IR-eyes are aligned and in range of each other (5-20 centimeters, or 2-8 inches). There must be no obstacles between the devices.

2. Choose the file you want to send. You have the following alternatives:

*Send a text file.* Enter **Notes** and select the file you want to send, then select **Beam** in the menu that appears.



Select **Beam**  
in the menu

*Send a contact.* Enter **C Address** and select the file you want to send, then select **Beam** in the menu that appears.

*Send a calendar event.* Enter **C Calendar** and select the file you want to send, then select **Beam** in the menu that appears.

*Send other files, saved in Storage.* Enter **Storage** and select the file you want to send, then select **Beam** in the menu that appears.

! *Please note* that only files can be sent, not folders.

3. C-Pen starts searching for the PDA device in order to send the file and the **Searching dialog box** appears on the screen.



*Searching  
dialog box*

4. During transmission, the file name is displayed in a dialog box together with a progress bar.
5. You can cancel the transmission at any time by pressing **CANCEL**.
6. When the transmission is complete a dialog box will appear, telling you whether the transmission was successful, or not.

---

## C Direct

**C Direct** gives you the opportunity to enter text from your C-Pen at the cursor position in any Windows program. To be able to use **C Direct**, C Win Software has to be installed on your PC. See **Using C-Pen with your PC**, p. 107.

The easiest way to control **C Direct** is from the **C Direct** icon in the system tray in Windows. By clicking on the icon, you can choose **Connect**, **Disconnect** or **Exit C Direct**. To activate **C Direct** you can simply double-click on the icon. For more information about how to use **C Direct**, please click your PC's Start button/Programs/C-Pen/C-Pen Help.

### Using IR

To activate **C Direct** place C-Pen in front of the IR port on your PC. Click the Start button/Programs/C-Pen/C Direct or click on the **C Direct** shortcut on your desktop.

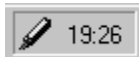

*the C Direct icon in the system tray*

The **C Direct** icon will appear in the system tray in the lower right-hand corner of your PC screen. The icon will be partly yellow when **C Direct** is connected, otherwise the icon is greyish.

The display on your C-Pen will show “C Direct”.

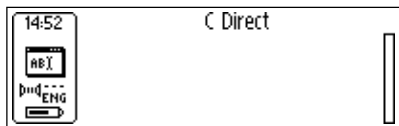

---

When you read text with C-Pen, it will appear as usual on C-Pen's display. To transfer the text to the Windows program, direct C-Pen's IR-eye towards the PC's IR port. The text will disappear from C-Pen's display and be transferred to the cursor position in the Windows program.

## Using cable

To activate **C Direct** make sure C-Pen is connected to your PC with the cable. Click the Start button/Programs/C-Pen/C Direct or click on the **C Direct** shortcut on your desktop.

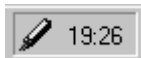

*the C Direct icon in the system tray*

The **C Direct** icon will appear in the system tray in the lower right corner of your screen. The icon will be partly yellow when **C Direct** is connected, otherwise the icon is greyish.

The display on your C-Pen will show "C Direct".

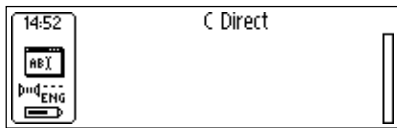

When you read text with C-Pen, the text will be transferred immediately to the cursor position in the Windows program. The text will not be visible in C-Pen's display.



---

## **C Write**

**C Write** is a feature that allows you to draw characters by using C-Pen as an ordinary pen. **C Write** makes it possible to quickly write new texts into your C-Pen but it is also an important tool during editing.

C-Pen can track its own movement over a surface and recognize the movement as a letter, digit or symbol. **C Write** is an alternative to using the character frame when inserting characters in a text.

The **C Write** application in the **Main menu** only gives information about the function.

For further information on using **C Write**, see p. 38.

---

## USING C-PEN WITH YOUR PC

A working connection with a PC is required to install and remove applications in C-Pen. To enable this communication certain hardware and software must be installed and configured properly on your PC.

The following is required for **IR** communication:

1. An IR port. Laptops often have a built-in IR port. Refer to your PC's manual to find out whether your PC is equipped with an IR port and if so, where it is located. Most desktop PCs do not have a built-in IR port. In this case you must use an external IR adapter. Contact your retailer if you do not have an IR adapter.
2. Infrared drivers are included on the C-Pen CD. It is crucial to install the infrared driver properly.
3. C-Win Software. This software is installed from the C-Pen CD.

The following is required for **cable** communication:

1. Cable. The cable is included in the C-Pen package.
2. COM port (serial port). The cable should be plugged into an available COM port on your PC.
3. C-Win Software. This software is installed from the C-Pen CD.

### Installing C-Win Software

C-Win Software and the infrared driver – if required – are installed when you run the installation programs on the C-Pen CD. The menu option **Documentation** on the C-Pen CD contains the *User's Guide* and *Help*. The installation

---

program also enables you to view *Tutorial videos*, which demonstrate how to use C-Pen for best results. Click the file you want to read.

To install C-Win Software (C-Win):

1. Put the C-Pen CD into your PC's CD-ROM drive and the installation program will start automatically. If installation does not start, click the Start button/Run and type `x:\cpen.exe`, where x: denotes the CD-ROM drive.
2. To install C-Win, click **Software installation**.

When C-Win is installed, the installation of C-Win communication settings (IR and/or cable) starts. If you have a C-Pen with a cable connection, you can choose to communicate by IR, cable or both. Please follow the instructions.

Infrared drivers might already be installed on your PC. The installation program will tell you if this is the case.

Infrared hardware on laptops can be configured in many different ways. Please follow the instructions in the installation program. If you have questions about IR communication, please click the Start button/Programs/C-Pen/Troubleshooting or go to [www.cpen.com/support](http://www.cpen.com/support) and click on Troubleshooting, or contact your laptop retailer or manufacturer.

## **Connecting C-Pen to a PC by IR**

To connect C-Pen to your PC, position C-Pen so that it is aligned with the PC's IR port as shown in the figure.

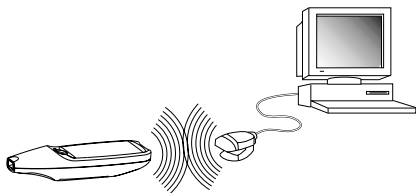

The installation program will place a C-Pen icon (*My C-Pen*) on your PC's desktop. When C-Pen is within range of the PC's IR port you can double-click on the icon. If communication is established between the PC's IR port and C-Pen, a communication icon will appear in the status field on C-Pen's display. 

On most laptops the built-in IR port - a red or black shiny plastic square - is found on the back or side of the computer.

## **Connecting C-Pen to a PC by Cable**

To connect a C-Pen to your PC, plug in the cable in C-Pen and in an available COM port on your PC.

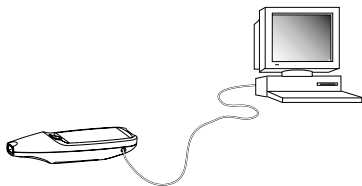

---

The installation program will place a C-Pen icon (*My C-Pen*) on your PC's desktop. When C-Pen is connected to your PC you can double-click on the icon. If the cable connection between C-Pen and the PC is in order, a communication icon will appear in the status field on C-Pen's display. 

## **Getting Help**

To get more detailed help using C-Win, open C-Pen Viewer (by double-clicking on the *My C-Pen* icon), from the *Help* menu select the *C-Pen Help Topics*. Or click your PC's Start button/Programs/C-Pen/C-Pen Help. You can also press F1 on the PC keyboard to enter the C-Win Software Help.

## **C-Pen Viewer**

Open C-Pen Viewer by double-clicking on the *My C-Pen* icon. C-Pen Viewer enables you to browse the contents of your C-Pen.

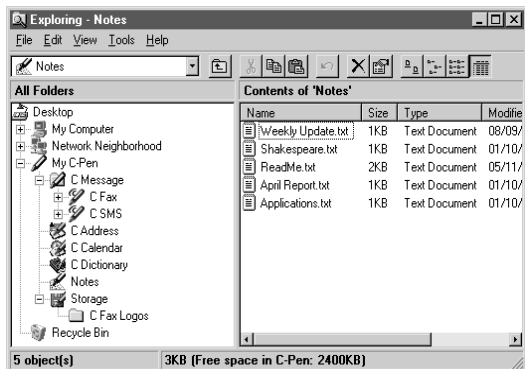

The user interface looks like Windows Explorer and you will recognize the applications from the **main screen** in C-Pen. Use C-Pen Viewer to open and browse files in your C-Pen, to create new folders and to remove applications from your C-Pen.

Your C-Pen Viewer might look different from the figure above, depending on which options you have enabled in the Explorer's View menu.

## Copy and paste in the PC environment

In the C-Pen Viewer you can view the details of the pen and also perform copy and paste operations.

One way of copying and pasting files is to use the **Edit menu** at the top of the active window on your desktop. Select the file you want to copy by clicking on it once.

---

Then click the **Edit menu** and select **Copy** in the menu that appears. Select the folder in which you want to put the copy. Then click the **Edit menu** and select **Paste**. A copy of the file is now placed in the selected folder.

Another way is to use “**drag and drop**”. Click the file you want to copy and keep the mouse button down. While keeping the mouse button down, move the mouse to point at the folder where you want to copy the file. Release the mouse button when the folder becomes highlighted. The file is now copied to the folder.

## **Installing and Removing Applications**

The applications in your C-Pen can be removed and new ones can be installed in the C-Pen Viewer. The C-Pen application’s file name is “.car” (C-Pen Archive). The files do not have to be placed in any specific folder on your PC, C-Pen will find them regardless.

To install a new application in C-Pen simply double-click on the “.car” file you want and installation will begin. You have to turn C-Pen off and on again to complete the process.

To remove an application from C-Pen select the application in the C-Pen Viewer and choose **Uninstall C-Pen Application** from the **File** menu and follow the instructions on the screen. You have to turn C-Pen off and on again to complete the process.

Some applications are part of the basic C-Pen functionality and cannot be uninstalled. To see if it is possible to uninstall an application, select it and open the **File** menu.

---

The application can be uninstalled if the menu option **Uninstall C-Pen Application** is enabled.

## Transferring Files

There are two ways to transfer files to and from C-Pen. Either between a PDA and C-Pen, or between C-Pen and a PC. It's practically the same as working with a floppy disk or a hard drive.

### Transferring files to and from a PC

Before transferring files you have to double-click on the *My C-Pen* icon on your PC in order to open the C-Pen Viewer. See **C-Pen Viewer**, p. 110.

**!** *Please note* that it is very important that communication functions properly. The IR-eyes of your PC and C-Pen must be aligned and in range of each other (5-20 centimeters or 2-8 inches). There must be no obstacles between the devices. If you use the cable, make sure that the cable is properly connected at both ends.

Find the file you want to transfer (e.g. a text file in **Notes**) and select it. Then copy the file and paste it into the desired folder on your PC. Please read **Copy and paste in the PC environment**, on p. 111.

When transferring files from the PC to C-Pen, remember that each application accepts only its own kind of files. **Notes**, for example, may only contain text files and **C Address** accepts only vCard files. Other file types can be saved in **Storage**, see **Storage**, p. 98.



---

## Transferring files to and from a PDA device

Files can be transferred to and from PDA devices if the PDA device supports the standard infrared protocol IrOBEX. Files are transferred with the application **C Beam**, see p. 100.

## C Address

**C Address**, the C-Pen address book, is available in the C-Pen Viewer on your PC. Double-clicking on **C Address** in the C-Pen Viewer presents the address files stored in C-Pen, listed by their contact name.

The address files are stored as vCard files (*filename.vcf*) and can be opened by a vCard viewer such as Netscape Communicator or Microsoft® Outlook/Microsoft® Outlook Express on your PC. Double-click on the file and then click **Yes** in the dialog box. *Please note* that this will open a copy of the file and that your changes will be saved on your PC, not in C-Pen.

To put an edited address file back into C-Pen, simply drag it from a folder on your PC and drop it into the **C Address** application in the C-Pen Viewer. *Note* that the dropped file cannot have the same name as an existing file in **C Address**. If it has the same name as a person already in the address book, a number is automatically attached at the end of the added person's name.

It is possible to synchronize your address files in **C Address** with those in Microsoft® Outlook (but not Microsoft® Outlook Express). Simply click your PC's Start button/Programs/C-Pen/C Sync. Selecting **C Sync** will start an easy-to-use application which allows you to specify the extent of synchronization.

- 
- ! **Please note** that this application only works if you have Microsoft® Outlook installed on your computer.

## C Direct

**C Direct** allows you to enter text from your C-Pen directly at the cursor position in any Windows program.

The **C Direct** application in the **C-Pen main screen** only gives information about the function. **C Direct** is activated from the PC and communicates by IR or cable. For further information on how to use **C Direct**, see p. 103.

## C-Pen Edit

**C-Pen Edit** is a simple text editor that provides basic text editing functions, such as cut, copy, paste, find and replace. It can communicate directly with your C-Pen to open and save files, when C-Pen and your PC are connected.

**C-Pen Edit** lets you edit files stored in C-Pen directly on your PC, without having to first move them to your PC. Double-click a text file in **Notes** in the C-Pen Viewer, and it will automatically be opened in **C-Pen Edit**. An opened file from C-Pen can be saved either to your PC or directly back into C-Pen. The same applies when you open a file from your PC.

## Closing the Connection

Close the connection between your C-Pen and your PC by selecting *Disconnect C-Pen* from the **File** menu in the C-Pen Viewer.

---

# TECHNICAL SPECIFICATIONS

## **C-Pen 600C**

Size: 140 x 35 x 24 mm (5.5 x 1.38 x 1.0 inches)

Weight: 80 g (3 oz) including batteries

Display: 2 or 4 rows

Flash memory: 6 MB

RAM: 4 MB

Battery: 2 x AAA, type LR03

Battery lifetime: 3-4 weeks of normal use

Reading speed: 15 cm/s (6 inches/s)

Character sizes: 5–22 points

## **C-Pen 800C**

Size: 140 x 35 x 20 mm (5.5 x 1.38 x 0.8 inches)

Weight: 85 g (3 oz)

Display: 5 or 7 rows

Flash memory: 8 MB

RAM: 4 MB

Battery: Rechargeable, NiMH

Battery lifetime: 2–3 weeks of normal use

Reading speed: 15 cm/s (6 inches/s)

Character sizes: 5–22 points

---

# WARRANTY

C Technologies AB warrants that this product is free from defects in materials and function at the time of original purchase and for a period of one year from that date. When the name C Technologies is mentioned in the following text, it means, unless otherwise stated, C Technologies AB (reg. number 556532-3929), its subsidiaries and retailers.

If, during the warranty period, any defect in the product arises due to a deficiency in materials or function, C Technologies pledges to, at C Technologies' option, either repair or replace the defective product with the same or an equivalent model.

C Technologies, however, takes no responsibility for:

1. Damage caused during shipping, by accidents, malicious damage, modification, incorrect usage, force majeure or any cause beyond the control of C Technologies, including but not limited to lightning, water, fire, public disturbances, riots, strike, war or other similar conflicts.
2. C Technologies is not responsible for damage (including but not limited to direct or indirect personal injury, lost profits, fall in production, losses of or alteration to processed information or any other incidental or consequential damages) caused by the product or the usage of the product or because the product cannot be used.
3. Deficient maintenance or a repair performed by unauthorized persons.
4. Incompatibility due to technological developments.
5. Defects caused by external equipment or abnormal wear.
6. Defects caused by normal wear and tear.

- 
7. Damage caused by the usage of inappropriate battery.
  8. Damage arising in connection with or as a consequence of upgrading with additions to or alterations of the product, using software or hardware not produced by or approved by C Technologies.

If your C-Pen product requires warranty service you should return the product to the dealer/retailer from whom it was purchased. The product must be packed in original packaging or with sufficient care so as to avoid shipping damage. The original purchaser must be able to show proof and date of purchase with receipt/invoice from point of purchase in order for this warranty to be valid.

Repair or exchange does not extend or renew the warranty period. Exchanged defective parts become the property of C Technologies. When the warranty period has expired, the warranty of exchanged/replaced parts also ceases.

This product is not to be regarded as having defects in materials or function if it must be rebuilt in order to be modified in accordance with national or local technical safety regulations in a country other than one that the product was meant to be used in.

C Technologies reserves all rights to the product, its hardware, software and trademark. Whoever buys or uses the product has no right to alter, disassemble, reverse engineer or in any other way use any part of the hardware or software in the product, except in the way and for the purposes permitted by law.

---

## LIMITED WORLDWIDE WARRANTY

To the extent such dealer/retailer has joined C Technologies' worldwide warranty program, you may, in addition to returning the product to the dealer/retailer from which it was purchased, also return the product to any dealer/retailer in the world carrying such product.

To the extent permissible under law, the warranties provided herein are exhaustive and constitute the sole and only warranties provided by C Technologies AB.

C TECHNOLOGIES' LIABILITY IN TORT (INCLUDING NEGLIGENCE) OR ARISING OUT OF ANY AGREEMENT FOR THE SALE, USE OR SUB-LICENSE OF THE PRODUCT SHALL BE LIMITED TO THE AMOUNT PAID BY PURCHASER FOR SUCH PRODUCT. IN NO EVENT, THE COMPANY WILL BE LIABLE UNDER ANY THEORY OF LIABILITY FOR ANY INDIRECT, INCIDENTAL, SPECIAL, EXEMPLARY OR CONSEQUENTIAL DAMAGES OF ANY KIND OR NATURE WHATSOEVER, SUFFERED BY THE PURCHASER, OR ANY OTHER PARTY, ANY END-USER, CUSTOMER, RESELLER, OR ANY DISTRIBUTOR, INCLUDING WITHOUT LIMITATION, LOST PROFITS, BUSINESS INTERRUPTIONS, LOSS OF DATA, OR OTHER ECONOMIC LOSS ARISING OUT OF THE POOR PERFORMANCE OR NON-PERFORMANCE HEREUNDER OR ANY USE OF OR FAILURE TO BE ABLE TO USE THE PRODUCT, EVEN IF SUCH PARTY HAS BEEN ADVISED OF THE POSSIBILITY OF SUCH DAMAGES AND NOTWITHSTANDING THE FAILURE OF ESSENTIAL PURPOSE OF ANY LIMITED REMEDY.

C TECHNOLOGIES MAKES AND PURCHASER RECEIVES NO WARRANTIES, OTHER THAN THOSE EXPRESSLY STATED IN THIS DOCUMENT, OR CONDITIONS ON THE PRODUCT, EXPRESSED, IMPLIED, CONTRACTUAL OR STATUTORY, AND C TECHNOLOGIES SPECIFICALLY DISCLAIMS ALL OTHER WARRANTIES AND REPRESENTATIONS INCLUDING WITHOUT LIMITATION ANY IMPLIED WARRANTY OF MERCHANTABILITY, NON-INFRINGEMENT OR FITNESS FOR A PARTICULAR PURPOSE, ANY WARRANTIES ARISING FROM A COURSE OF DEALING, USAGE OR TRADE PRACTICE AND ANY WARRANTIES CONCERNING THE NON-INFRINGEMENT OF THIRD PARTY RIGHT.

---

## Warranty Information

Serial number:

CT number:

Date:

Customer:

Address:

Dealer:

Address:







---

# Declaration of Conformity

C Technologies AB (publ)  
Ideon Research Park  
Scheelevägen 15  
SE-223 70 Lund  
Sweden

hereby declares the products

C-Pen 600C (product No. CT 151 010)  
C-Pen 800C (product No. CT 151 011)  
C-Pen 600MX (product No. CT 151 014)

to comply with the EMC directive 89/336/EEC, fulfilling the requirements of the standards

EN 50 081-1 (1992): Electromagnetic compatibility,  
Generic Emission Standard  
EN 55 022: Electromagnetic compatibility, Basic Standard  
EN 50 082-1 (1997): Electromagnetic compatibility,  
Generic Immunity Standard  
EN 61 000-4-2: Electromagnetic compatibility, Basic Standard  
EN 61 000-4-3: Electromagnetic compatibility, Basic Standard  
ENV 50 204: Electromagnetic compatibility, Basic Standard

Lund, January 09, 2001

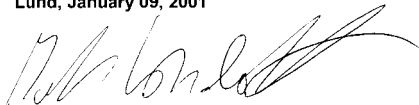

Mats Lindoff  
CEO  
C Technologies AB (publ)

---

## **UL STATEMENT**

All UL-labelled C-Pen products fulfill the requirements of the UL 1950 standard: UL Standard for Safety of Information Technology Equipment.

C-Pen models with built-in rechargeable batteries are to be used with Direct Plug-In Transformer unit marked “Class 2” rated from 4.05-4.95 Vdc, 450-550 mA.

The built-in rechargeable batteries are not operator accessible or replaceable.

---

## C DICTIONARY COPYRIGHT NOTICE

Copyrights for the following dictionaries are held by their respective publisher. Copyright information for additional titles from current and/or additional publishers made available by C Technologies after this publication goes to print will be listed at [www.cdictionary.com](http://www.cdictionary.com).

- Norstedts Ordbok is a trademark of Norstedts Ordbok HB, Teknologgatan 8c, Stockholm, Sweden
- Norstedts engelska (Engelsk-svensk/Svensk-engelsk) ordbok  
Copyright © 1994 Norstedts Ordbok AB, All rights reserved
- Norstedts tyska (Tysk-svensk/Svensk-tysk) ordbok  
Copyright © 1998 Norstedts Ordbok AB, All rights reserved
- Norstedts fransk (Fransk-svensk/Svensk-Fransk) ordbok  
Copyright © 1989 Norstedts Ordbok AB, All rights reserved
- “Oxford University Press” and “Oxford” are registered trademarks of Oxford University Press, Great Clarendon Street, Oxford, England
- Concise Oxford Thesaurus © Oxford University Press 1995 –Additional Material © Market House Books Ltd. 1995

- 
- Concise Oxford Hachette French Dictionary © Oxford University Press 1995, 1998  
© Hachette Livre 1995, 1998
  - Concise Oxford-Duden German Dictionary © Oxford University Press and Bibliographisches Institut & F.A. Brockhaus AG 1991, 1997, 1998
  - Concise Oxford Spanish Dictionary © Oxford University Press 1995, 1998
  - Oxford Zanichelli Concise Dictionary ©1997  
Zanichelli editore S.p.A.
  - Concise Oxford Dictionary 10<sup>th</sup> edition © Oxford University Press 1999
  - “Merriam-Webster’s” is a registered trademark of Merriam-Webster Incorporated, 47 Federal Street, Springfield, Massachusetts, USA
  - Merriam-Webster’s Collegiate® Dictionary Copyright © 2000 by Merriam-Webster, Incorporated
  - Merriam-Webster’s Collegiate® Thesaurus Copyright © 1988 by Merriam-Webster, Incorporated

# INDEX

## A

Alarm 95

Application icon 18

Applications 46

  C Address 46, 52

  C Beam 47, 100

  C Calendar 46, 58

  C Dictionary 46, 72

  C Direct 47, 103

  C Message 46, 81

  C Write 47, 105

  Info 47, 97

  Notes 48

  Settings 47, 89

  Storage 98

Autotrigger 16, 96

## B

Battery 21

Battery Compartment 17

Battery power level 23

## C

C Address 8, 52

  C Address main screen 52

  Contact edit screen 52

  Contact list 52

  Contact menu 54

  Delete a contact 57

  Edit a contact 56

  Enter a new contact 52

  Find a contact 56

  Find contact screen 56

  Options 54

  Saving a file 54

  Synchronizing address files  
    113

  Using C Address 52

  vCard files 113

  View a contact 55

C Beam 8, 47, 100

  Accept dialog 101

  Folders 102

  Receive dialog 100

  Save files 101

  Searching dialog 102

  Using C Beam 100

C Calendar 9, 46, 58

  Alarm 66, 71

  Back/Forward button 61

  Checked/unchecked task 69

  Create event 63

  Create task 67

  Day button 59, 62

  Day view 62

  Delete event/task 69

  Details screen 68

  Event edit screen 64

  Event options 65

  Event/Task information 68

  Exit 71

  Find an event 69

  Find... 61

  Main menu 59

  Menu button 59

  Month button 59, 63

  Month view 63

  Repeat button 66

  Repeat options 66

  Settings 70

  Task button 59

  Task edit screen 68

  Task list 67

- Using C Calendar 58
- View buttons 58
- Week button 59, 62
- Week view 62
- C Dictionary 9, 46, 72
  - Dictionaries button 79
  - Dictionary licence key 74
  - Exit C Dictionary 80
  - Info button 80
  - Installing a dictionary from C-Pen CD 72
  - Installing a dictionary from the web 73
  - Remove dictionary 73
  - Text language 79
  - Translation screen 77
  - Word edit box 76
  - Word references 77
  - Word selection list 78
  - Word selection screen 79
- C Direct 8, 47, 103, 114
  - Using cable 104
  - Using IR 103
- C Fax Logos 88
- C Message 9, 46, 81
  - Add to C Address button 85
  - C Fax Logos 88
  - C Fax options 86
  - C SMS main screen 83
  - C SMS options 86
  - Contact list 84
  - Criteria 81
  - Download logotype/footer 88
  - Email gateway 86
  - Email options 86
  - Footer 88
  - Logotype 87
  - Message setup screen 85
  - Resolution 88
  - Send 85
  - Send file stored in Notes 82
  - Settings 87
  - SMS-Email options 86
  - Unsent 83, 84, 85
  - Using C Message 81
- C Read 8, 28, 48
- C SMS main screen 83
- C SMS options 86
- C Write 8, 38, 47, 105
  - Basic rules 39
  - C Write Feedback 39
  - C Write Prototypes 42
  - Capital letters 40
  - Symbols 40
  - Using C Write 39
- C Write Prototypes 42
- C-Pen
  - Battery Compartment 17
  - Camera Opening 17
  - Reset 23
- C-Pen 600C 6
  - Cable Connector 17
- C-Pen 800C 7
  - Autotrigger 16
  - Charging connector 17
  - Reset 17, 24
  - Temperature 24
- C-Pen Edit 114
- C-Pen models 5
  - C-Pen 600C 6
  - C-Pen 800C 7

- C-Pen Viewer 109
- Cable communication
  - C-Win software 106
  - Cable 106
  - COM port 106
- Cable Connector 17
- Calibration 91
  - How to... 92, 93
  - Quick 92
- Camera Opening 17
- Character set 35
- Character size 11
- Charging connector 17
- Check box 19, 27
- Closing the connection 114
- Command menu 49
- Connecting C-Pen to a PC by cable 108
- Connecting C-Pen to a PC by IR 107
- Contact list 84
- Contact menu 54
- Contrast 95
- Copy and paste on a PC 110
  - Drag and drop 111
  - Edit menu 110
- Create event 63
- Create task 67
- Creating a folder 48
- Cursor 50

**D**

- Day view 62
- Delete event/ task 69
- Details screen 68
  - Check/Uncheck 69
- Dialog box 20
- Dialog button 20, 26
- Dictionaries button 79
- Dictionary licence key 74
- Display 16
- Display object 18
- Download dictionary 73
- Download footer 88
- Download logotype 88

**E**

- Edit field 20, 26
- Edit menu 33
  - Change 38
  - Cut, Copy and Paste 37
  - Delete 37
  - Insert 36
  - Quit Editing 38
  - Select 37
  - Settings 37
- Edit mode 33
- Editing text 33
  - C Write 38
  - Edit menu 33
  - Edit mode symbol 33
  - Entering edit mode 33
- Email gateway 86
- ESC 16

Event 63  
  Edit screen 65  
  Options 65  
Event/task info 68  
Exchange Trigger/ESC 96

## **F**

Fax options 86  
Features 8  
File 48  
  Beam 50, 55, 98  
  Creating a new file 48  
  Delete 49  
  Open 49  
  Properties 50  
  Rename 49  
  Send 50  
Find an event 69  
Footer 88

## **G**

Getting started 21  
  Battery 21  
  Turning C-Pen On and Off  
  21

## **H**

Help 12

## **I**

Info 47, 97  
  C-Pen facts 97  
  Getting started 97  
  Troubleshooting 97  
Infrared drivers 106

## **Installing**

  Applications 111  
  C-Win Software 106  
Installing a dictionary from C-  
  Pen CD 72  
Installing a dictionary from the  
  web 73  
Installing C Beam 100  
Installing C-Win software 106  
Introduction to C-Pen 5  
Inverted text 90  
IR communication  
  C-Win software 106  
  Infrared driver 106  
  IR port 106  
IR port 16, 108  
Ir protocol 100

## **L**

Language, setting 90  
Left/Right hand 96  
Logotype 87

## **M**

Main screen 18  
Menu 19, 26  
  ESC 26  
  Selecting 25  
Menu language 96  
Message setup screen 85  
Month view 63



## **N**

- Nav 16
- Navigation control (Nav) 25
- Notes 48
  - Command menu 49
  - Create new file or folder 48
  - Edit / C Write 51
  - List of text files 48
  - Text menu 50
  - Using C Read/Notes 48

## **O**

- OCR 10
- On/Off button 16, 21
- Optimum reading conditions 10

## **P**

- PDA 100
- Pin code 94
- Power off time 96

## **R**

- Read mode
  - Line break 90
  - Tab 90
- Reading conditions 10
- Reading text 28
  - Deleting a line 32
  - Text screen 31
- Remove dictionary 73
- Removing applications 111
- Reset 17, 24

## **S**

- Saving text 32
- Selecting 25
- Send file in Notes 82
- Settings 47, 89
  - C Write Feedback 39, 90
  - Calibration 91
  - Modify a setting 89
  - Read Mode 90
  - System settings 94
  - Text Language 90
  - Text Quality 90
- SMS-Email options 86
- Sound 95
- Status field 18
- Storage 9, 98
  - Delete file 98
  - File properties 98
  - Open file 98
  - Using Storage 98
- Support 12, 97
- Synchronizing address files 113
- System Settings 94
  - Contrast 95
  - Exchange Trigger/ESC 96
  - Font 96
  - Left/Right Hand 96
  - Menu Language 96
  - PIN code 94
  - Power off time 96
  - Sound 95
  - Time 95

## **T**

- Task 67
- Task edit screen 68
- Task list 67
- Technical Specifications 115
  - C-Pen 600C 115
  - C-Pen 800C 115
- Temperature 24
- Text colors 11
- Text, inverted 90
- Text Language 90
- Text Language icon
  - 18, 22, 23
- Text menu 50
- Text Quality 90
- Text Quality icon
  - 18, 22, 23, 93, 94
- Text screen 31
- Text settings 89
- Time 95
- Transferring files 112
  - Copy and paste 112
  - To/from your PC 112
  - To/from your PDA 113
- Trigg 16
- Troubleshooting 12, 97
- Turning C-Pen On and Off 21

## **U**

- Using C Address 52
- Using C Calendar 58

- Using C Dictionary 75
- Using C Direct (cable) 104
- Using C Direct (IR) 103
- Using C Message 81
- Using C-Pen with your PC
  - 106
  - C Address 113
  - C Direct 114
  - Cable communication 106
  - Closing the connection 114
  - Getting help 109
  - IR communication 106
- Using C-Write 38
- Using Notes/C Read 48
- Using Storage 98

## **V**

- View buttons 58

## **W**

- Week view 62



